

GENERATOR SET

Power Ratings

Voltage, Frequency	PRP	ESP
400V, 50Hz cosφ = 0.8	70kVA / 56kW	77kVA / 62kW

Engine Make / Model :	SDEC - SC4H95D2
Generator Make / Model :	ALR - AA224F
Control Panel :	ComAp AMF 9 Lite
Charge Alternator [V / A] :	24.0 / 55-Negative
Battery Charger [V / A] :	27.3 / 5
Battery / Capacity [V / Ah] :	2 x (12 / 72)
Block Water Heater [W] :	1000
ATS Model / Length x Width x Dept * :	125A / 550x200x450

Fuel Consumption

Load	110%	100%	75%	50%
[lt / h]	16,8	15	11,4	8
Fuel Tank Capacity [lt] Open skid / Canopied :	170 / 160			

Based on diesel fuel with a specific gravity of 0.85 and conforming to TS EN590 Class A2

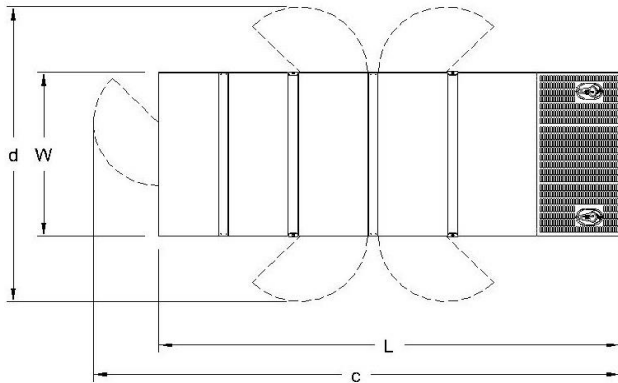

Diesel Engine

Manufacturer :	SDEC
Engine Model :	SC4H95D2
No. of Cylinders / Alignment :	4 / Inline
Bore / Stroke [mm] :	105 / 124
Compression Ratio :	17,3 : 1
Displacement [lt] :	4,3
Engine Speed [rpm] :	1500
Gross Engine Power ESP / PRP [kW] :	68 / 62

Generator

Manufacturer :	ALR
Alternator Model :	AA224F
Bearings Type :	Single
Insulation Class :	H
Winding Pitch :	2/3
No. of Wires Terminal :	6
Frequency / Poles :	50Hz / 4p
Voltage (Ph-Ph / Ph-N) :	400V / 230V
Output Power (163°C / 27°C) :	82kVA / 64kW

Prime Power (PRP)

A Prime rated generator set is capable of providing power to a varying load for an unlimited number of hours per year. Ten percent overload is allowed at one in 12 hours.

Emergency Standby Power (ESP)

A Standby rated generator set is capable of providing max. power to a varying load for 200 hours per year. No overload is allowed.

Standard Reference Conditions

A specified values are given for 25°C ambient temperature, 100m above sea level and 30% relative humidity.

Dimensions & Weights

	L x W x H (mm) / c x d (mm)	Wet (kg)
Canopy :	2550x1100x1730 / RFI	1390
	L x W x H (mm) / a x b x h (mm)	Wet (kg)
W/O Canopy :	2100X900X1450 / 620X650X570	1050

Dry = Without any liquid

Wet = With lube oil, coolant and fuel

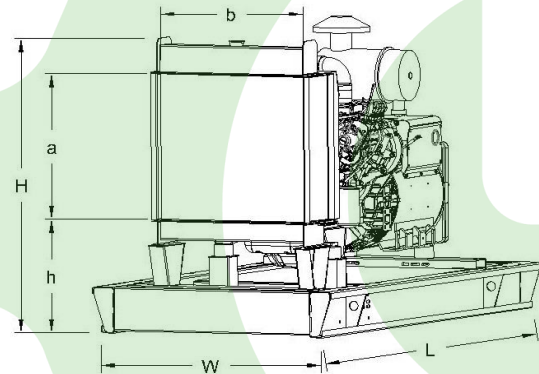

Air Intake System :	Turbocharged
Governor Type / Class 8528 :	Electronic / G2
Total Oil Capacity [lt] :	13
Oil Type :	API CI-4, CH4/ 15W-40
Cooling System Capacity [lt] :	24,8
Recommended Fuel :	TS EN590, Class A2 Diesel
Emissions Compliance :	Stage II
Housing - Flywheel :	3-11.5

Regulation Type / Model :	AVR / SX440	
Protection Class :	IP23	
Efficiency (Pf 0,8 Prime)	90,2%	
Voltage Regulation (Steady State) :	± 1.0%	
THD (Total Harmonic Distortion) :	< 3.5%	
	15%	RFI kVA
Voltage Dip.	25%	RFI kVA
	30%	RFI kVA

f = 50Hz, cosφ = 0 is for given.