

GENERATOR SET

Power Ratings

Voltage, Frequency	PRP	ESP
400V, 50Hz cosφ = 0.8	550kVA / 440kW	600kVA / 480kW
Engine Make / Model :	SDEC - SC25G690D2	
Generator Make / Model :	Leroy Somer / TAL047D	
Control Panel :	ComAp AMF 9 Lite	
Charge Alternator [V / A] :	24.0 / 55-Negative	
Battery Charger [V / A] :	27.3 / 5	
Battery / Capacity [V / Ah] :	2 x (12 / 150)	
Block Water Heater [W] :	2X2000 with pump	
ATS Model / Length x Width x Height * :	1000A / 1000x850x320	

Fuel Consumption

Load	110%	100%	75%	50%
[lt / h]	127,9	113,8	85,9	60,7
Fuel Tank Capacity [lt - h] Open skid / Canopied :	740 / 900			

Based on diesel fuel with a specific gravity of 0.85 and conforming to TS EN590 Class A2



Diesel Engine

Manufacturer :	SDEC
Engine Model :	SC25G690D2
No. of Cylinders / Alignment :	12 / V
Bore / Stroke [mm] :	135 / 150
Compression Ratio :	16,0 : 1
Displacement [lt] :	25,8
Engine Speed [rpm] :	1500
Gross Engine Power ESP / PRP [kW] :	505 / 459

Generator

Manufacturer :	Leroy Somer
Alternator Model :	TAL047D
Bearings Type :	Single
Insulation Class :	H
Winding Pitch :	2/3
No. of Wires Terminal :	6
Frequency / Poles :	50Hz / 4p
Voltage (Ph-Ph / Ph-N) :	400V / 230V
Output Power (163°C / 27°C) :	600 kVA / 480 kW

Prime Power (PRP)

A Prime rated generator set is capable of providing power to a varying load for an unlimited number of hours per year. Ten percent overload is allowed at one in 12 hours.

Emergency Standby Power (ESP)

A Standby rated generator set is capable of providing max. power to a varying load for 200 hours per year. No overload is allowed.

Standard Reference Conditions

A specified values are given for 25°C ambient temperature, 100m above sea level and 30% relative humidity.

Dimensions & Weights

	L x W x H (mm) / c x d (mm)	Wet (kg)
Canopy :	3900x1800x3030 / RFI	5740
	L x W x H (mm) / a x b x h (mm)	Wet (kg)
W/O Canopy :	3700X1500X2330 / 1280X1340X680	4845

Dry = Without any liquid

Wet = With lube oil, coolant and fuel

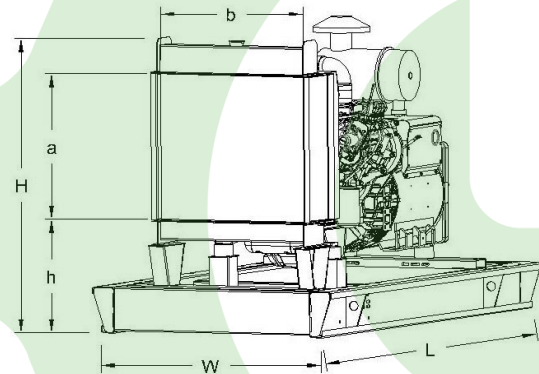

Air Intake System :	Turbocharged & Intercooled
Governor Type / Class 8528 :	Electronic / G2
Total Oil Capacity [lt] :	65
Oil Type :	API CI-4, CH4/ 15W-40
Cooling System Capacity [lt] :	105
Recommended Fuel :	TS EN590, Class A2 Diesel
Emissions Compliance :	Stage II
Housing - Flywheel :	0-18

Regulation Type / Model :	AVR / R150
Protection Class :	IP23
Efficiency :	94,7%
Voltage Regulation (Steady State) :	± 1.0%
THD (Total Harmonic Distortion) :	< 1,5.0% w/o load/ < 5 % on load
	15% 395 kVA
Voltage Dip.	25% 730 kVA
	30% 930 kVA

f = 50Hz, cos φ = 0,6 , motor starting SHUNT is for given.