

GENERATOR SET

Power Ratings

Voltage, Frequency	PRP	ESP
400V, 50Hz cosφ = 0.8	400kVA / 320kW	440kVA / 352kW
Engine Make / Model :	SDEC - SC15G500D2	
Generator Make / Model :	Leroy Somer / TAL047A	
Control Panel :	ComAp AMF 9 Lite	
Charge Alternator [V / A] :	24.0 / 55-Negative	
Battery Charger [V / A] :	27.3 / 5	
Battery / Capacity [V / Ah] :	2 x (12 / 150)	
Block Water Heater [W] :	2000	
ATS Model / Length x Width x Depth * :	700A / 850x300x850	

Fuel Consumption

Load	110%	100%	75%	50%
[lt / h]	90,3	81,2	59,8	41,1
Fuel Tank Capacity [lt - h] Open skid / Canopied :	500 / 570			

Based on diesel fuel with a specific gravity of 0.85 and conforming to TS EN590 Class A2



Prime Power (PRP)

A Prime rated generator set is capable of providing power to a varying load for an unlimited number of hours per year. Ten percent overload is allowed at one in 12 hours.

Emergency Standby Power (ESP)

A Standby rated generator set is capable of providing max. power to a varying load for 200 hours per year. No overload is allowed.

Standard Reference Conditions

A specified values are given for 25°C ambient temperature, 100m above sea level and 30% relative humidity.

Dimensions & Weights

	L x W x H (mm) / c x d (mm)	Wet (kg)
Canopy :	3350x1400x2730 / RFI	4120
	L x W x H (mm) / a x b x h (mm)	Wet (kg)
W/O Canopy :	3200X1300X2001 / 1210X1150X620	3290

Dry = Without any liquid

Wet = With lube oil, coolant and fuel

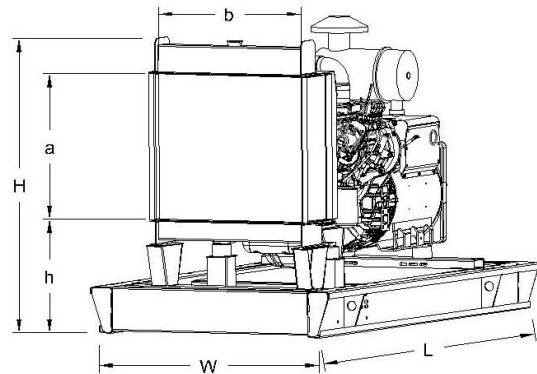

Diesel Engine

Manufacturer :	SDEC
Engine Model :	SC15G500D2
No. of Cylinders / Alignment :	6 / Inline
Bore / Stroke [mm] :	135 / 165
Compression Ratio :	15,5 : 1
Displacement [lt] :	14,2
Engine Speed [rpm] :	1500
Gross Engine Power ESP / PRP [kW] :	363 / 330

Generator

Manufacturer :	Leroy Somer
Alternator Model :	TAL047A
Bearings Type :	Single
Insulation Class :	H
Winding Pitch :	2/3
No. of Wires Terminal :	6
Frequency / Poles :	50Hz / 4p
Voltage (Ph-Ph / Ph-N) :	400V / 230V
Output Power (27°C)	450 kVA / 360 kW

Air Intake System :	Turbocharged & Intercooled
Governor Type / Class 8528 :	Electronic / G2
Total Oil Capacity [lt] :	41
Oil Type :	API CI-4, CH4/ 15W-40
Cooling System Capacity [lt] :	96
Recommended Fuel :	TS EN590, Class A2 Diesel
Emissions Compliance :	Stage II
Housing - Flywheel :	1-14

Regulation Type / Model :	AVR / R150
Protection Class :	IP23
Efficiency (Pf 0,8 Prime)	93,4%
Voltage Regulation (Steady State) :	± 1.0%
THD (Total Harmonic Distortion) :	< 3,5.0% w/o load/ < 5 % on load
	15% 220 kVA
Voltage Dip.	25% 470 kVA
	30% 605 kVA

f = 50Hz, motor starting is SHUNT, cosφ = 0,6 is for given.