

## GENERATOR SET

### Power Ratings

Voltage, Frequency	PRP	ESP
400V, 50Hz cosφ = 0.8	300kVA / 240kW	330kVA / 264kW
Engine Make / Model :	SDEC - SC10E380D2	
Generator Make / Model :	Leroy Somer / TAL046F	
Control Panel :	ComAp AMF 9 Lite	
Charge Alternator [V / A] :	28.0 / 70-Negative	
Battery Charger [V / A] :	27.3 / 5	
Battery / Capacity [V / Ah] :	2 x (12 / 150)	
Block Water Heater [W] :	1500	
ATS Model / Length x Width x Dept * :	500A / 750x750x300	

### Fuel Consumption

Load	110%	100%	75%	50%
[lt / h]	67,5	60,8	49,4	32,1
Fuel Tank Capacity [lt - h] Open skid / Canopied :	500 / 570			

Based on diesel fuel with a specific gravity of 0.85 and conforming to TS EN590 Class A2



### Diesel Engine

Manufacturer :	SDEC
Engine Model :	SC10E380D2
No. of Cylinders / Alignment :	6 / Inline
Bore / Stroke [mm] :	128 / 135
Compression Ratio :	17,0 : 1
Displacement [lt] :	11,8
Engine Speed [rpm] :	1500
Gross Engine Power ESP / PRP [kW] :	280 / 255

### Generator

Manufacturer :	Leroy Somer
Alternator Model :	TAL046F
Bearings Type :	Single
Insulation Class :	H
Winding Pitch :	2/3
No. of Wires Terminal :	6
Frequency / Poles :	50Hz / 4p
Voltage (Ph-Ph / Ph-N) :	400V / 230V
Output Power ( 125°C / 40°C ) :	330kVA / 264kW

### Prime Power (PRP)

A Prime rated generator set is capable of providing power to a varying load for an unlimited number of hours per year. Ten percent overload is allowed at one in 12 hours.

### Emergency Standby Power (ESP)

A Standby rated generator set is capable of providing max. power to a varying load for 200 hours per year. No overload is allowed.

### Standard Reference Conditions

A specified values are given for 25°C ambient temperature, 100m above sea level and 30% relative humidity.

### Dimensions & Weights

	L x W x H (mm) / c x d (mm)	Wet (kg)
Canopy :	3350x1400x2730 / RFI	4020 / RFI
	L x W x H (mm) / a x b x h (mm)	Wet (kg)
W/O Canopy :	3200x1300x2001 / 1210x1150x660	2350 / RFI

Dry = Without any liquid

Wet = With lube oil, coolant and fuel

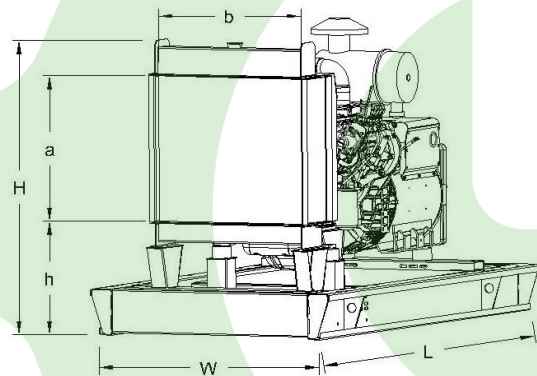

Air Intake System :	Turbocharged & Intercooled
Governor Type / Class 8528 :	Electronic / G2
Total Oil Capacity [lt] :	41
Oil Type :	API CI-4, CH4/ 15W-40
Cooling System Capacity [lt] :	23,2 (Engine Only)
Recommended Fuel :	TS EN590, Class A2 Diesel
Emissions Compliance :	Stage II
Housing - Flywheel :	1-14

Regulation Type / Model :	AVR / R150
Protection Class :	IP23
Efficiency (Pf 0,8 Prime) :	92.3%
Voltage Regulation (Steady State) :	± 1.0%
THD (Total Harmonic Distortion) :	< 2,5% w/o load/ < 5 % on load
	15% 265kVA
Voltage Dip.	25% 505kVA
	30% 650kVA

f = 50Hz, Voltage dip is given for Locked rotor at P.F.=0.6 .