

## GENERATOR SET

### Power Ratings

Voltage, Frequency	PRP	ESP
400V, 50Hz cosφ = 0.8	250kVA / 200kW	275kVA / 220kW

Engine Make / Model :	SDEC - SC9D340D2
Generator Make / Model :	Leroy Somer / TAL046D
Control Panel :	ComAp AMF 9 Lite
Charge Alternator [V / A] :	24.0 / 55-Negative
Battery Charger [V / A] :	27.3 / 5
Battery / Capacity [V / Ah] :	2 x (12 / 120)
Block Water Heater [W] :	1500
ATS Model / Length x Width x Depth * :	400A / 750x300x750

### Fuel Consumption

Load	110%	100%	75%	50%
[lt / h]	59,6	54,1	40,8	27,3

Fuel Tank Capacity [lt - h @ %75 load] Open skid / Canopied : 350-8,5/380-9,3

Based on diesel fuel with a specific gravity of 0.85 and conforming to TS EN590 Class A2

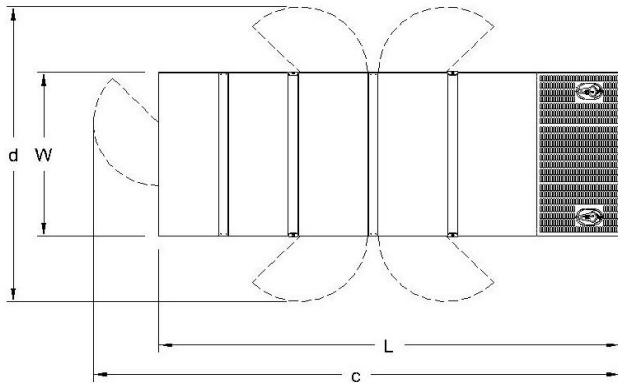

### Diesel Engine

Manufacturer :	SDEC
Engine Model :	SC9D340D2
No. of Cylinders / Alignment :	6 / Inline
Bore / Stroke [mm] :	114 / 144
Compression Ratio :	16,5 : 1
Displacement [lt] :	8,9
Engine Speed [rpm] :	1500
Gross Engine Power ESP / PRP [kW] :	250 / 228

### Generator

Manufacturer :	Leroy Somer
Alternator Model :	TAL046D
Bearings Type :	Single
Insulation Class :	H
Winding Pitch :	2/3
No. of Wires Terminal :	6
Frequency / Poles :	50Hz / 4p
Voltage (Ph-Ph / Ph-N) :	400V / 230V
Output Power ( 163°C / 27°C ) :	275kVA / 220kW

### Prime Power (PRP)

A Prime rated generator set is capable of providing power to a varying load for an unlimited number of hours per year. Ten percent overload is allowed at one in 12 hours.

### Emergency Standby Power (ESP)

A Standby rated generator set is capable of providing max. power to a varying load for 200 hours per year. No overload is allowed.

### Standard Reference Conditions

A specified values are given for 25°C ambient temperature, 100m above sea level and 30% relative humidity.

### Dimensions & Weights

	L x W x H (mm) / c x d (mm)	Wet (kg)
Canopy :	3400x1250x2110 / RFI	2900
	L x W x H (mm) / a x b x h (mm)	Wet (kg)
W/O Canopy :	2600X1050X1800 / 970X860X610	2200

Dry = Without any liquid

Wet = With lube oil, coolant and fuel

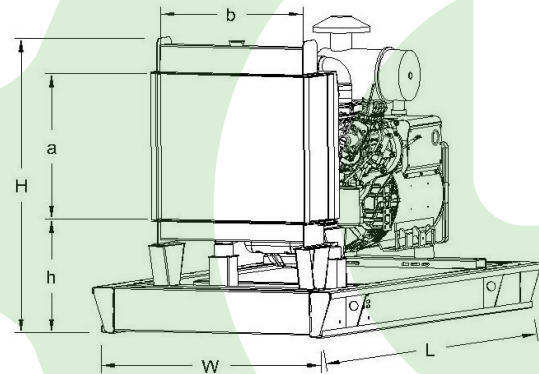

Air Intake System :	Turbocharged & Intercooled
Governor Type / Class 8528 :	Electronic / G2
Total Oil Capacity [lt] :	25
Oil Type :	API CI-4, CH4/ 15W-40
Cooling System Capacity [lt] :	42,5
Recommended Fuel :	TS EN590, Class A2 Diesel
Emissions Compliance :	Stage II
Housing - Flywheel :	2-11.5

Regulation Type / Model :	AVR / R150
Protection Class :	IP23
Efficiency (Pf 0,8 Prime) :	91,3%
Voltage Regulation (Steady State) :	± 1.0%
THD (Total Harmonic Distortion) :	< 2,5% w/o load/ < 5 % on load
	15% 150kVA
Voltage Dip.	25% 290kVA
	30% 365kVA

f = 50Hz, Voltage dip is given for Locked rotor at P.F.=0.6 .