

GENERATOR SET

Power Ratings

Voltage, Frequency	PRP	ESP
400V, 50Hz cosφ = 0.8	241kVA / 192,8kW	265kVA / 212kW
Engine Make / Model :	SDEC - SC9D310D2	
Generator Make / Model :	ALR - AA274K	
Control Panel :	ComAp AMF 9 Lite	
Charge Alternator [V / A] :	28.0 / 55-Negative	
Battery Charger [V / A] :	24 / 5	
Battery / Capacity [V / Ah] :	2 x (12 V / 105 Ah)	
Block Water Heater [W, V] :	1500 W , 230 V	
ATS Model / Length x Width x Height * :	400A / 750x750x300	

Fuel Consumption

Load	110%	100%	75%	50%
[lt / h]	55,6	50,6	38,2	26,3
Fuel Tank Capacity [lt - h @ %75 load]	Open skid / Canopied : 350 - 9,16 / 10,7			
Based on diesel fuel with a specific gravity of 0.85 and conforming to TS EN590 Class A2				

Prime Power (PRP)

A Prime rated generator set is capable of providing power to a varying load for an unlimited number of hours per year. Ten percent overload is allowed at one in 12 hours.

Emergency Standby Power (ESP)

A Standby rated generator set is capable of providing max. power to a varying load for 200 hours per year. No overload is allowed.

Standard Reference Conditions

A specified values are given for 25°C ambient temperature, 100m above sea level and 30% relative humidity.

Dimensions & Weights

	L x W x H (mm) / c x d (mm)	Wet (kg)
Canopy :	3100x1250x2060 / RFI	2320
	L x W x H (mm) / a x b x h (mm)	Wet (kg)
W/O Canopy :	2600X1050X1700 / 970X860X610	1930

Dry = Without any liquid

Wet = With lube oil, coolant and fuel

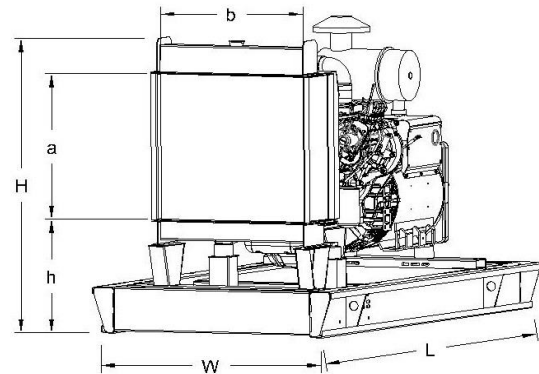
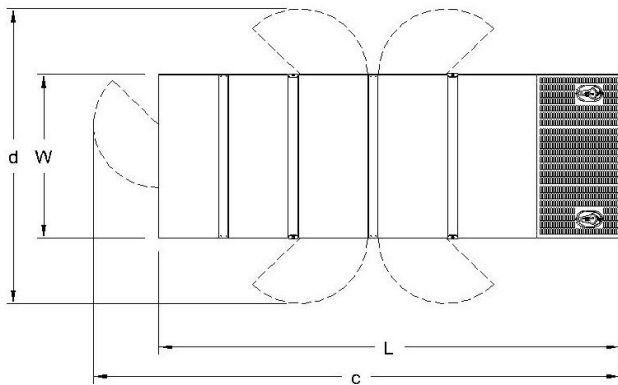

Diesel Engine

Manufacturer :	SDEC
Engine Model :	SC9D310D2
No. of Cylinders / Alignment :	6 / Inline
Bore / Stroke [mm] :	114 / 144
Compression Ratio :	18 : 1
Displacement [lt] :	8,82
Engine Speed [rpm] :	1500
Gross Engine Power ESP / PRP [kW] :	250 / 228

Generator

Manufacturer :	ALR
Alternator Model :	AA274K
Bearings Type :	Single
Insulation Class :	H
Winding Pitch :	2/3
No. of Wires Terminal :	6
Frequency / Poles :	50Hz / 4p
Voltage (Ph-Ph / Ph-N) :	400V / 230V
Output Power (125°C / 40°C) :	250kVA / 200kW

Air Intake System :	Turbocharged & Intercooled
Governor Type / Class 8528 :	Electronic / G2
Total Oil Capacity [lt] :	19
Oil Type :	API CI-4, CH4/ 15W-40
Cooling System Capacity [lt] :	38
Recommended Fuel :	TS EN590, Class A2 Diesel
Emissions Compliance :	Stage II
Housing - Flywheel :	2-11.5

Regulation Type / Model :	AVR / SX440	
Protection Class :	IP23	
Efficiency :	91,7%	
Voltage Regulation (Steady State) :	± 1.0%	
THD (Total Harmonic Distortion) :	< 3.5%	
	15%	RFI kVA
Voltage Dip.	25%	RFI kVA
	29%	RFI kVA

f = 50Hz, cos φ = 0 is for given.