

GENERATOR SET

Power Ratings

| Voltage, Frequency | PRP | ESP |
|---------------------------------------|--------------------|----------------|
| 400V, 50Hz cosφ = 0.8 | 210kVA / 168kW | 230kVA / 184kW |
| Engine Make / Model : | SDEC - SC9D280D2 | |
| Generator Make / Model : | ALR - AA274H | |
| Control Panel : | ComAp AMF 9 Lite | |
| Charge Alternator [V / A] : | 24.0 / 55-Negative | |
| Battery Charger [V / A] : | 27.3 / 5 | |
| Battery / Capacity [V / Ah] : | 2 x (12 / 105) | |
| Block Water Heater [W] : | 1500 | |
| ATS Model / Length x Width x Dept * : | 350A / 750x300x750 | |

Fuel Consumption

| Load | 110% | 100% | 75% | 50% |
|--|-------------|------|------|------|
| [lt / h] | 53,6 | 48,6 | 36,2 | 24,3 |
| Fuel Tank Capacity [lt - h] Open skid / Canopied : | 330-7/370-8 | | | |

Based on diesel fuel with a specific gravity of 0.85 and conforming to TS EN590 Class A2

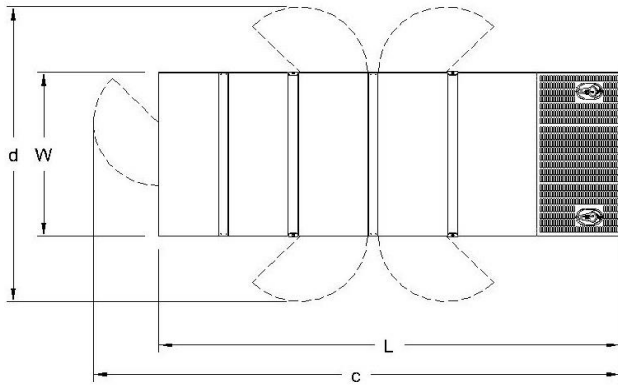

Diesel Engine

| | |
|-------------------------------------|------------|
| Manufacturer : | SDEC |
| Engine Model : | SC9D280D2 |
| No. of Cylinders / Alignment : | 6 / Inline |
| Bore / Stroke [mm] : | 114 / 135 |
| Compression Ratio : | 18,0 : 1 |
| Displacement [lt] : | 8,27 |
| Engine Speed [rpm] : | 1500 |
| Gross Engine Power ESP / PRP [kW] : | 204 / 185 |

Generator

| | |
|---------------------------------|----------------|
| Manufacturer : | ALR |
| Alternator Model : | AA274H |
| Bearings Type : | Single |
| Insulation Class : | H |
| Winding Pitch : | 2/3 |
| No. of Wires Terminal : | 6 |
| Frequency / Poles : | 50Hz / 4p |
| Voltage (Ph-Ph / Ph-N) : | 400V / 230V |
| Output Power (163°C / 27°C) : | 230kVA / 184kW |

Prime Power (PRP)

A Prime rated generator set is capable of providing power to a varying load for an unlimited number of hours per year. Ten percent overload is allowed at one in 12 hours.

Emergency Standby Power (ESP)

A Standby rated generator set is capable of providing max. power to a varying load for 200 hours per year. No overload is allowed.

Standard Reference Conditions

A specified values are given for 25°C ambient temperature, 100m above sea level and 30% relative humidity.

Dimensions & Weights

| | L x W x H (mm) / c x d (mm) | Wet (kg) |
|--------------|---------------------------------|----------|
| Canopy : | 3100x1250x2060 / RFI | 2280 |
| | L x W x H (mm) / a x b x h (mm) | Wet (kg) |
| W/O Canopy : | 2600X1050X1700 / 880X880X700 | 1930 |

Dry = Without any liquid

Wet = With lube oil, coolant and fuel

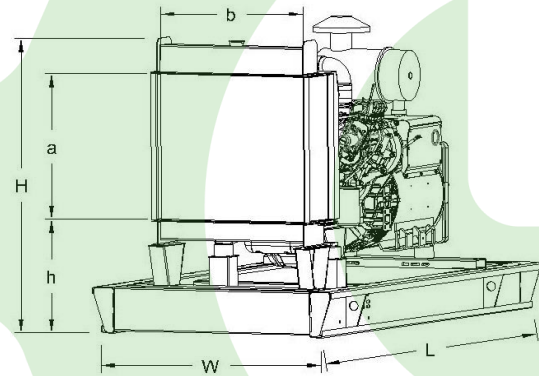

| | |
|--------------------------------|----------------------------|
| Air Intake System : | Turbocharged & Intercooled |
| Governor Type / Class 8528 : | Electronic / G2 |
| Total Oil Capacity [lt] : | 19 |
| Oil Type : | API CI-4, CH4/ 15W-40 |
| Cooling System Capacity [lt] : | 39,5 |
| Recommended Fuel : | TS EN590, Class A2 Diesel |
| Emissions Compliance : | Stage II |
| Housing - Flywheel : | 2-11.5 |

| | | |
|-------------------------------------|-------------|---------|
| Regulation Type / Model : | AVR / SX440 | |
| Protection Class : | IP23 | |
| Efficiency : | 93,3% | |
| Voltage Regulation (Steady State) : | ± 1.0% | |
| THD (Total Harmonic Distortion) : | < 3.5% | |
| | 15% | RFI kVA |
| Voltage Dip. | 25% | RFI kVA |
| | 30% | RFI kVA |

f = 50Hz, cos φ = 0 is for given.