

GENERATOR SET

Power Ratings

Voltage, Frequency	PRP	ESP
400V, 50Hz cosφ = 0.8	190kVA / 152kW	210kVA / 168kW
Engine Make / Model :	SDEC - SC7H250D2	
Generator Make / Model :	ALR - AA274H	
Control Panel :	ComAp AMF 9 Lite	
Charge Alternator [V / A] :	24.0 / 55-Negative	
Battery Charger [V / A] :	27.3 / 5	
Battery / Capacity [V / Ah] :	2 x (12 / 105)	
Block Water Heater [W] :	1500	
ATS Model / Length x Width x Dept * :	315A / 750x300x750	

Fuel Consumption

Load	110%	100%	75%	50%
[lt / h]	40,5	36,5	27,3	18,2
Fuel Tank Capacity [lt - h] Open skid / Canopied :	215-6/270-7			

Based on diesel fuel with a specific gravity of 0.85 and conforming to TS EN590 Class A2



Diesel Engine

Manufacturer :	SDEC
Engine Model :	SC7H250D2
No. of Cylinders / Alignment :	6 / Inline
Bore / Stroke [mm] :	105 / 124
Compression Ratio :	16,0 : 1
Displacement [lt] :	6,5
Engine Speed [rpm] :	1500
Gross Engine Power ESP / PRP [kW] :	185 / 168

Generator

Manufacturer :	ALR
Alternator Model :	AA274H
Bearings Type :	Single
Insulation Class :	H
Winding Pitch :	2/3
No. of Wires Terminal :	6
Frequency / Poles :	50Hz / 4p
Voltage (Ph-Ph / Ph-N) :	400V / 230V
Output Power (163°C / 27°C) :	230kVA / 184kW

Prime Power (PRP)

A Prime rated generator set is capable of providing power to a varying load for an unlimited number of hours per year. Ten percent overload is allowed at one in 12 hours.

Emergency Standby Power (ESP)

A Standby rated generator set is capable of providing max. power to a varying load for 200 hours per year. No overload is allowed.

Standard Reference Conditions

A specified values are given for 25°C ambient temperature, 100m above sea level and 30% relative humidity.

Dimensions & Weights

	L x W x H (mm) / c x d (mm)	Wet (kg)
Canopy :	3400x1100x2020 / RFI	2790
	L x W x H (mm) / a x b x h (mm)	Wet (kg)
W/O Canopy :	2600X900X1600 / 890X800X460	1600

Dry = Without any liquid

Wet = With lube oil, coolant and fuel

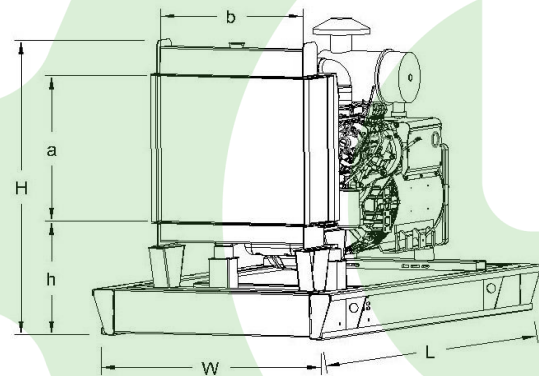

Air Intake System :	Turbocharged & Intercooled
Governor Type / Class 8528 :	Electronic / G2
Total Oil Capacity [lt] :	17,5
Oil Type :	API CI-4, CH4/ 15W-40
Cooling System Capacity [lt] :	31,1
Recommended Fuel :	TS EN590, Class A2 Diesel
Emissions Compliance :	Stage II
Housing - Flywheel :	3-11.5

Regulation Type / Model :	AVR / SX440	
Protection Class :	IP23	
Efficiency (Pf 0,8 Prime)	93,3%	
Voltage Regulation (Steady State) :	± 1.0%	
THD (Total Harmonic Distortion) :	< 3.5%	
	15%	RFI kVA
Voltage Dip.	25%	RFI kVA
	30%	RFI kVA

f = 50Hz, cos φ = 0 is for given.