

GENERATOR SET

Power Ratings

Voltage, Frequency	PRP	ESP
400V, 50Hz cosφ = 0.8	650kVA / 520kW	715kVA / 572kW

Engine Make / Model :	Scania -DC16093A 02-54
Generator Make / Model :	Leroy Somer - TAL047F
Control Panel :	ComAp Inteligen AMF9
Charge Alternator [V / A] :	28V / 100A
Battery Charger [V / A] :	27.3 / 5
Battery / Capacity [V / Ah] :	2 x 180 Ah
Block Water Heater [W] :	2 X 2000 W / 230V + 1 pump
ATS Model / Length x Width x Dept * :	ATS 1050A / 1000X850X320

Fuel Consumption

Load	110%	100%	75%	50%
[lt / h]	143,02	129,32	93,05	63,34

Fuel Tank Capacity [lt] : open skid - 795 lt / Canopied - 1100 lt

Based on diesel fuel with a specific gravity of 0.85 and conforming to TS EN590 Class A2

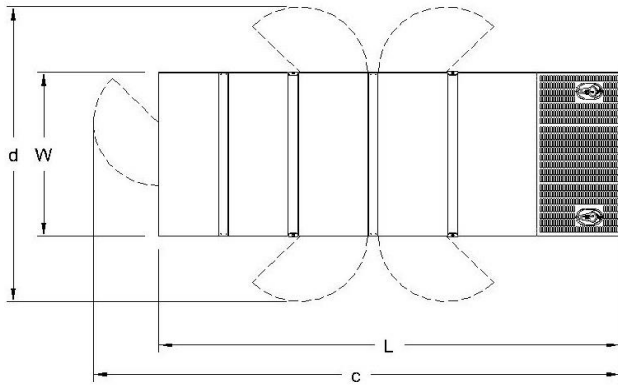

Diesel Engine

Manufacturer :	Scania
Engine Model :	DC16093A 02-54
No. of Cylinders / Alignment :	8V
Bore / Stroke [mm] :	130 / 154
Compression Ratio :	16,7/1
Displacement [lt] :	16,4
Engine Speed [rpm] :	1500
Gross Engine Power ESP / PRP [kW] :	614 / 558

Generator

Manufacturer :	Leroy Somer
Alternator Model :	TAL047F
Bearings Type :	Single
Insulation Class :	H
Winding Pitch :	2/3
No. of Wires Terminal :	6
Frequency / Poles :	50Hz / 4p
Voltage (Ph-Ph / Ph-N) :	400V / 230V
Output Power (163°C / 27°C) :	730 kVA / 584 kW

Prime Power (PRP)

A Prime rated generator set is capable of providing power to a varying load for an unlimited number of hours per year. Ten percent overload is allowed at one in 12 hours.

Emergency Standby Power (ESP)

A Standby rated generator set is capable of providing max. power to a varying load for 200 hours per year. No overload is allowed.

Standard Reference Conditions

A specified values are given for 25°C ambient temperature, 100m above sea level and 30% relative humidity.

Dimensions & Weights

	L x W x H (mm) / c x d (mm)	Wet (kg)
Canopy :	4100 x 1600 x 2550 / 4350 x 2700	5025
	L x W x H (mm) / a x b x h (mm)	Wet (kg)
W/O Canopy :	3360 x 1350 x 2200 / 1720 x 1120 x 300	3680

Dry = Without any liquid

Wet = With lube oil, coolant and fuel

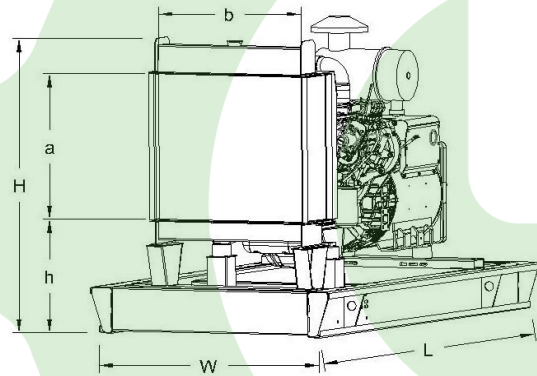

Air Intake System :	Turbocharged / Intercooled
Governor Type / Class 8528 :	Electronic-EDC4
Total Oil Capacity [lt] :	45
Oil Type :	API CI-4 / 15W-40
Cooling System Capacity [lt] :	68
Recommended Fuel :	TS EN590, Class A2 Diesel
Emissions Compliance :	Tier II
Housing - Flywheel :	SAE 1/14

Regulation Type / Model :	AVR / R150	
Protection Class :	IP23	
Efficiency (Pf 0,8 Prime)	94,9%	
Voltage Regulation (Steady State) :	± 1.0%	
THD (Total Harmonic Distortion) :	< 1,5.0% w/o load/ < 5 % on load	
	15%	450 kVA
Voltage Dip.	25%	630 kVA
	30%	870 kVA

f = 50Hz, cos φ = 0,6, motor starting SHUNT is for given.