

GENERATOR SET

Power Ratings

Voltage, Frequency	PRP	ESP
400V, 50Hz cosφ = 0.8	600kVA / 480kW	660kVA / 528kW
Engine Make / Model :	Scania - DC16093A 02-53	
Generator Make / Model :	Leroy Somer - TAL047E	
Control Panel :	ComAp Inteligen AMF9	
Charge Alternator [V / A] :	28V / 100A	
Battery Charger [V / A] :	27.3 / 5	
Battery / Capacity [V / Ah] :	2 x 180 Ah	
Block Water Heater [W] :	2 X 2000 W / 230	
ATS Model / Length x Width x Dept * :	ATS 1050A / 1000X300X850	

Fuel Consumption

Load	110%	100%	75%	50%
[lt / h]	135,57	120,11	88,21	60,36
Fuel Tank Capacity [lt - h] :	open skid - 680 lt / Canopied - 990 lt			
Based on diesel fuel with a specific gravity of 0.85 and conforming to TS EN590 Class A2				

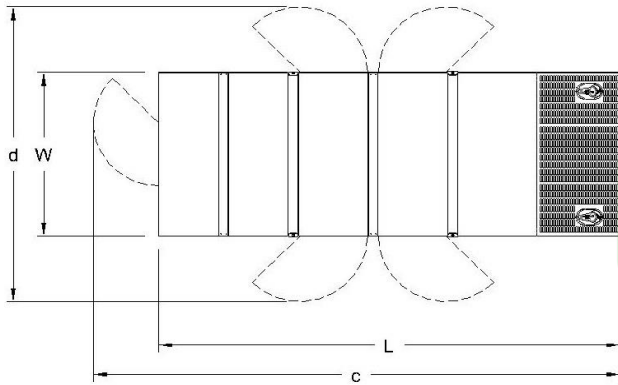

Diesel Engine

Manufacturer :	Scania
Engine Model :	DC16093A 02-53
No. of Cylinders / Alignment :	8V
Bore / Stroke [mm] :	130 / 154
Compression Ratio :	16,7/1
Displacement [lt] :	16,4
Engine Speed [rpm] :	1500
Gross Engine Power ESP / PRP [kW] :	582 / 529

Generator

Manufacturer :	Leroy Somer
Alternator Model :	TAL047E
Bearings Type :	Single
Insulation Class :	H
Winding Pitch :	2/3
No. of Wires Terminal :	6
Frequency / Poles :	50Hz / 4p
Voltage (Ph-Ph / Ph-N) :	400V / 230V
Output Power (163°C / 27°C) :	660 kVA / 528 kW

Prime Power (PRP)

A Prime rated generator set is capable of providing power to a varying load for an unlimited number of hours per year. Ten percent overload is allowed at one in 12 hours.

Emergency Standby Power (ESP)

A Standby rated generator set is capable of providing max. power to a varying load for 200 hours per year. No overload is allowed.

Standard Reference Conditions

A specified values are given for 25°C ambient temperature, 100m above sea level and 30% relative humidity.

Dimensions & Weights

	L x W x H (mm) / c x d (mm)	Wet (kg)
Canopy :	4100 x 1600 x 2550 / 4350 x 2700	4850 kg
	L x W x H (mm) / a x b x h (mm)	Dry (kg)
W/O Canopy :	3360 x 1350 x 2200 / 1720 x 1120 x 300	3630 kg

Dry = Without any liquid

Wet = With lube oil, coolant and fuel

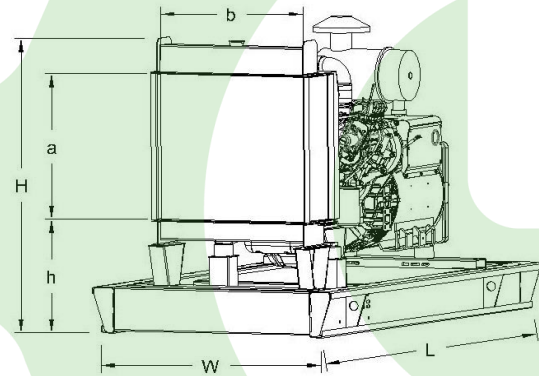

Air Intake System :	Turbocharged / Intercooled
Governor Type / Class 8528 :	Electronic-EDC4
Total Oil Capacity [lt] :	45
Oil Type :	API CI-4 / 15W-40
Cooling System Capacity [lt] :	68
Recommended Fuel :	TS EN590, Class A2 Diesel
Emissions Compliance :	Tier II
Housing - Flywheel :	SAE 1/14

Regulation Type / Model :	AVR / R150
Protection Class :	IP23
Efficiency :	94,6%
Voltage Regulation (Steady State) :	± 1.0%
THD (Total Harmonic Distortion) :	< 1,5.0% w/o load/ < 5 % on load
	15% 400 kVA
Voltage Dip.	25% 585 kVA
	30% 730 kVA

f = 50Hz, cos φ = 0,6 , motor starting SHUNT is for given.