

## GENERATOR SET

### Power Ratings

Voltage, Frequency	PRP	ESP
400V, 50Hz cosφ = 0.8	1522kVA / 1218kW	1650kVA / 1320kW

Engine Make / Model :	MHI - S12R-PTAA2
Generator Make / Model :	Leroy Somer - LSA50.2 L8
Control Panel :	ComAp AMF 9 Lite
Charge Alternator [V / A] :	24.0 / 30-Negative
Battery Charger [V / A] :	27.3 / 5
Battery / Capacity [V / Ah] :	4 x (12 / 200)
Block Water Heater [W] :	2 x 2000W
ATS Model / Length x Width x Height * :	2500 A / 1400 x 1700 x 700

### Fuel Consumption

Load	110%	100%	75%	50%
[lt / h]	352	319	239	166

Fuel Tank Capacity [lt] : External fuel tank 2500

Based on diesel fuel with a specific gravity of 0.85 and conforming to TS EN590 Class A2

### Prime Power (PRP)

A Prime rated generator set is capable of providing power to a varying load for an unlimited number of hours per year. Ten percent overload is allowed at one in 12 hours.

### Emergency Standby Power (ESP)

A Standby rated generator set is capable of providing max. power to a varying load for 200 hours per year. No overload is allowed.

### Standard Reference Conditions

A specified values are given for 25°C ambient temperature, 100m above sea level and 30% relative humidity.

### Dimensions & Weights

	L x W x H (mm) / c x d (mm)	Wet (kg)
Canopy :	5600x2450x4270 / TBA	12635
	L x W x H (mm) / a x b x h (mm)	Wet (kg)
W/O Canopy :	5000X2250X2844 / 1800x2157x725	11000

Dry = Without any liquid

Wet = With lube oil, coolant and fuel

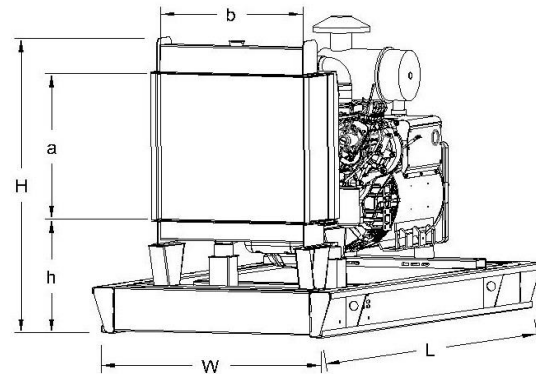
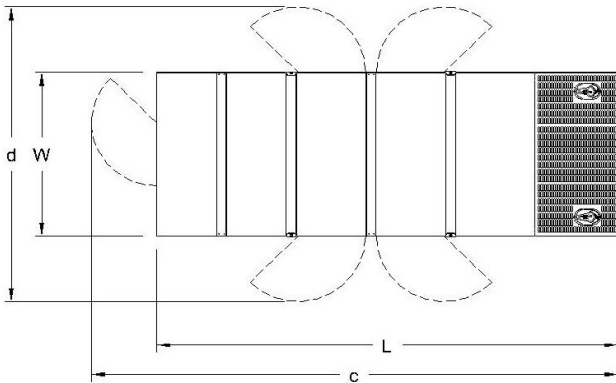

### Diesel Engine

Manufacturer :	MHI
Engine Model :	S12R-PTAA2
No. of Cylinders / Alignment :	12 / V
Bore / Stroke [mm] :	170 / 180
Compression Ratio :	13,5 : 1
Displacement [lt] :	49,03
Engine Speed [rpm] :	1500
Gross Engine Power ESP / PRP [kW] :	1441 / 1314

### Generator

Manufacturer :	Leroy Somer
Alternator Model :	LSA50.2 L8
Bearings Type :	Single
Insulation Class :	H
Winding Pitch :	2/3
No. of Wires Terminal :	6
Frequency / Poles :	50Hz / 4p
Voltage (Ph-Ph / Ph-N) :	400V / 230V
Output Power ( 163°C / 27°C ) :	1650kVA / 1320kW

Air Intake System :	Turbocharged & Intercooled
Governor Type / Class 8528 :	Electronic / G2
Total Oil Capacity [lt] :	230
Oil Type :	API CI-4, CH4/ 15W-40
Cooling System Capacity [lt] :	350
Recommended Fuel :	TS EN590, Class A2 Diesel
Emissions Compliance :	TBA
Housing - Flywheel :	00-21

Regulation Type / Model :	AVR / R450	
Protection Class :	IP23	
Efficiency :	95.4%	
Voltage Regulation (Steady State) :	± 0.5%	
THD (Total Harmonic Distortion) :	< 3.5%	
	15%	1450kVA
Voltage Dip.	25%	2800kVA
	29%	3500kVA

f = 50Hz, Voltage drops given for locked rotor.