

GENERATOR SET

Power Ratings

Voltage, Frequency	PRP	ESP
400V, 50Hz cosφ = 0.8	1286kVA / 1029kW	1415kVA / 1132kW
Engine Make / Model :	MHI - S12R-PTA	
Generator Make / Model :	Leroy Somer - LSA50.2 L7	
Control Panel :	ComAp AMF 9 Lite	
Charge Alternator [V / A] :	24.0 / 30-Negative	
Battery Charger [V / A] :	27.3 / 5	
Battery / Capacity [V / Ah] :	4 x 200 Ah	
Block Water Heater [W] :	2 X 2000 W / 230V	
ATS Model / Length x Width x Height * :	ATS 2000A / 1400X1750X750	

Fuel Consumption

Load	110%	100%	75%	50%
[lt / h]	286	260	197	136
Fuel Tank Capacity [lt] : External fuel tank	2000			

Based on diesel fuel with a specific gravity of 0.85 and conforming to TS EN590 Class A2



Prime Power (PRP)

A Prime rated generator set is capable of providing power to a varying load for an unlimited number of hours per year. Ten percent overload is allowed at one in 12 hours.

Emergency Standby Power (ESP)

A Standby rated generator set is capable of providing max. power to a varying load for 200 hours per year. No overload is allowed.

Standard Reference Conditions

A specified values are given for 25°C ambient temperature, 100m above sea level and 30% relative humidity.

Dimensions & Weights

	L x W x H (mm) / c x d (mm)	Wet (kg)
Canopy :	5000x2250x3870 / TBA	11130
	L x W x H (mm) / a x b x h (mm)	Wet (kg)
W/O Canopy :	4250X2040X2550 / 1825x1900x400	9500

Dry = Without any liquid

Wet = With lube oil, coolant and fuel

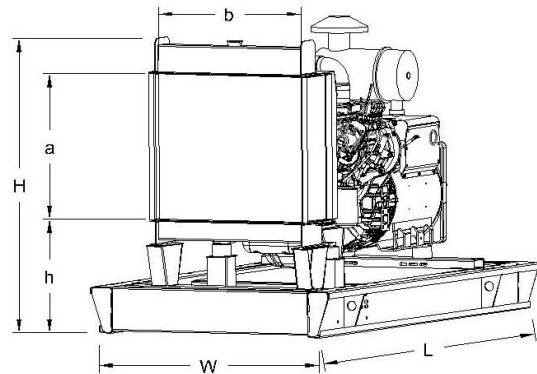

Diesel Engine

Manufacturer :	MHI
Engine Model :	S12R-PTA
No. of Cylinders / Alignment :	12 / V
Bore / Stroke [mm] :	170 / 180
Compression Ratio :	15,0 : 1
Displacement [lt] :	49,03
Engine Speed [rpm] :	1500
Gross Engine Power ESP / PRP [kW] :	1220 / 1110

Generator

Manufacturer :	Leroy Somer
Alternator Model :	LSA50.2 L7
Bearings Type :	Single
Insulation Class :	H
Winding Pitch :	2/3
No. of Wires Terminal :	6
Frequency / Poles :	50Hz / 4p
Voltage (Ph-Ph / Ph-N) :	400V / 230V
Output Power (163°C / 27°C) :	1485kVA / 1188kW

Air Intake System :	Turbocharged & Intercooled
Governor Type / Class 8528 :	Electronic / G2
Total Oil Capacity [lt] :	180
Oil Type :	API CI-4, CH4/ 15W-40
Cooling System Capacity [lt] : (Engine only)	125
Recommended Fuel :	TS EN590, Class A2 Diesel
Emissions Compliance :	TBA
Housing - Flywheel :	00-21

Regulation Type / Model :	AVR / R450	
Protection Class :	IP23	
Efficiency :	95.3%	
Voltage Regulation (Steady State) :	± 0.5%	
THD (Total Harmonic Distortion) :	< 3.5%	
	15%	1350kVA
Voltage Dip.	25%	2480kVA
	29%	3150kVA

f = 50Hz, Voltage drops given for locked rotor.