

GENERATOR SET

Power Ratings

Voltage, Frequency	PRP	ESP
400V, 50Hz cosφ = 0.8	300kVA / 240kW	330kVA / 264kW
Engine Make / Model :	Deutz - BF6M1015C-LA G2A	
Generator Make / Model :	ALR - AA314E	
Control Panel :	ComAp AMF 9 Lite	
Charge Alternator [V / A] :	28,5 / 55	
Battery Charger [V / A] :	24 / 5	
Battery / Capacity [V / Ah] :	2 x (12V / 120Ah)	
Block Water Heater [W, V] :	2 x (1500 W, 230V)	
ATS Model / Length x Width x Height * :	ATS 500A / 750X750X300	

Fuel Consumption

Load	110%	100%	75%	50%
[lt / h]	TBA	60	45,3	31,1
Fuel Tank Capacity [lt] : Open skid / Canopied :	290 / 510			

Based on diesel fuel with a specific gravity of 0.85 and conforming to TS EN590 Class A2



Diesel Engine

Manufacturer :	Deutz
Engine Model :	BF6M1015C-LA G2A
No. of Cylinders / Alignment :	6V
Bore / Stroke [mm] :	132 / 145
Compression Ratio :	16,5 : 1
Displacement [lt] :	11,9
Engine Speed [rpm] :	1500
Gross Engine Power ESP / PRP [kW] :	285 / 260

Generator

Manufacturer :	ALR
Alternator Model :	AA314E
Bearings Type :	Single
Insulation Class :	H
Winding Pitch :	2/3
No. of Wires Terminal :	6
Frequency / Poles :	50Hz / 4p
Voltage (Ph-Ph / Ph-N) :	400V / 230V
Output Power (163°C / 27°C) :	355kVA / 280kW

Prime Power (PRP)

A Prime rated generator set is capable of providing power to a varying load for an unlimited number of hours per year. Ten percent overload is allowed at one in 12 hours.

Emergency Standby Power (ESP)

A Standby rated generator set is capable of providing max. power to a varying load for 200 hours per year. No overload is allowed.

Standard Reference Conditions

A specified values are given for 25°C ambient temperature, 100m above sea level and 30% relative humidity.

Dimensions & Weights

	L x W x H (mm) / c x d (mm)	Wet (kg)
Canopy :	3000X1700X2890 / TBA	3050
	L x W x H (mm) / a x b x h (mm)	Wet (kg)
W/O Canopy :	2850X1200X2010 / 1240 x 1060 x 360	2500

Dry = Without any liquid

Wet = With lube oil, coolant and fuel

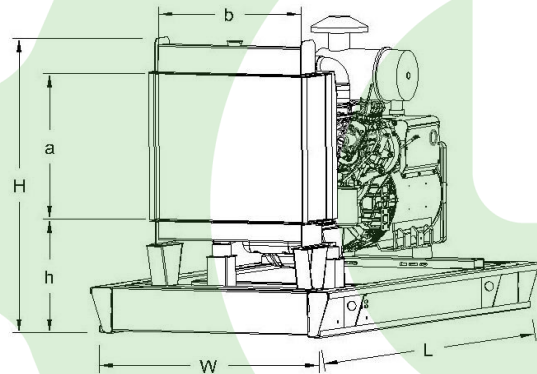

Air Intake System :	Turbo Charged, Inter Cooler
Governor Type / Class 8528 :	Electronic
Total Oil Capacity [lt] :	38
Oil Type :	API CI-4, CH4/ 15W-40
Cooling System Capacity [lt] :	95
Recommended Fuel :	TS EN590, Class A2 Diesel
Emissions Compliance :	N/A
Housing - Flywheel :	SAE1/14

Regulation Type / Model :	AVR / SX440	
Protection Class :	IP23	
Efficiency (Pf 0,8 Prime) :	93,5%	
Voltage Regulation (Steady State) :	± 1.0%	
THD (Total Harmonic Distortion) :	< 3.5%	
	15%	RFI kVA
Voltage Dip.	25%	RFI kVA
	30%	RFI kVA

f = 50Hz, cosφ = 0 is for given.