

GENERATOR SET

Power Ratings

Voltage, Frequency	PRP	ESP
400V, 50Hz cosφ = 0.8	409,3kVA / 327,4kW	451kVA / 360,8 kW

Engine Make / Model :	Cummins - QSG12G2
Generator Make / Model :	Leroy Somer - TAL047A
Control Panel :	ComAp Inteligen AMF9
Charge Alternator [V / A] :	24V / 80A
Battery Charger [V / A] :	24 / 5
Battery / Capacity [V / Ah] :	2 x 150 Ah
Block Water Heater [W] :	2000 W / 230V
ATS Model / Length x Width x Dept * :	700A / 850 x 850 x 300

Fuel Consumption

Load	110%	100%	75%	50%
[lt / h]	92	82	60	41

Fuel Tank Capacity [lt - h] : 500 ltrs open skid 570 ltrs canopied

Based on diesel fuel with a specific gravity of 0.85 and conforming to TS EN590

Class A2

* Optional Item

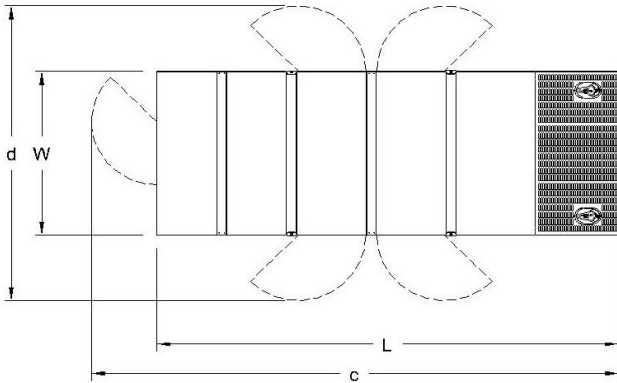

Prime Power (PRP)

A Prime rated generator set is capable of providing power to a varying load for an unlimited number of hours per year. Ten percent overload is allowed at one in 12 hours.

Emergency Standby Power (ESP)

A Standby rated generator set is capable of providing max. power to a varying load for 200 hours per year. No overload is allowed.

Standard Reference Conditions

A specified values are given for 25°C ambient temperature, 100m above sea level and 30% relative humidity.

Dimensions & Weights

	L x W x H (mm) / c x d (mm)	Wet (kg)
Canopy :	3350 x 1400 x 2970 / TBA	3565 kg
	L x W x H (mm) / a x b x h (mm)	Wet (kg)
W/O Canopy :	3200 x 1300 x 2046 / 1210 x 1200 710	2650 kg

Dry = Without any liquid

Wet = With lube oil, coolant and fuel

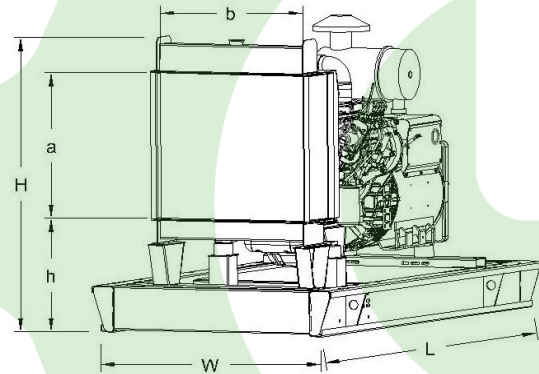

Diesel Engine

Manufacturer :	Cummins
Engine Model :	QSG12G2
No. of Cylinders / Alignment :	6L
Bore / Stroke [mm] :	132 / 144
Compression Ratio :	17,0/1
Displacement [lt] :	11,8
Engine Speed [rpm] :	1500
Gross Engine Power ESP / PRP [kW] :	409 / 371

Generator

Manufacturer :	Leroy Somer
Alternator Model :	TAL047A
Bearings Type :	Single
Insulation Class :	H
Winding Pitch :	2/3
No. of Wires Terminal :	6
Frequency / Poles :	50Hz / 4p
Voltage (Ph-Ph / Ph-N) :	400V / 230V
Output Power (163°C / 27°C) :	450 kVA / 360 kW

Air Intake System :	Turbo Charged, Air Cooled
Governor Type / Class 8528 :	Electronic / G2
Total Oil Capacity [lt] :	34,1
Oil Type :	API CI-4 / 15W-40
Cooling System Capacity [lt] :	48
Recommended Fuel :	TS EN590, Class A2 Diesel
Emissions Compliance :	N/A
Housing - Flywheel :	SAE 1

Regulation Type / Model :	AVR / R150
Protection Class :	IP23
Efficiency (Pf 0,8 Prime)	93,3%
Voltage Regulation (Steady State) :	± 1.0%
THD (Total Harmonic Distortion) :	< 3,5.0% w/o load/ < 5 % on load
	15% 220 kVA
Voltage Dip.	25% 470 kVA
	30% 605 kVA

f = 50Hz, motor starting is SHUNT, cosφ = 0,6 is for given.