

GENERATOR SET

Power Ratings

Voltage, Frequency	PRP	ESP
400V, 50Hz cosφ = 0.8	40kVA / 32kW	44kVA / 35kW

Engine Make / Model :	Cummins S3.8G4
Generator Make / Model :	Leroy Somer - TAL042E
Control Panel :	ComAp Inteligen AMF9
Charge Alternator [V / A] :	14V / 53A
Battery Charger [V / A] :	12 / 35
Battery / Capacity [V / Ah] :	1 x 60 Ah
Block Water Heater [W] :	500 W / 230V
ATS Model / Length x Width x Dept * :	ATS 80A / 550X200X450

Fuel Consumption

Load	110%	100%	75%	50%
[lt / h]	11,2	9,9	7,6	5,4

Fuel Tank Capacity [lt - h] : 120 ltrs open skid 105 ltrs canopied

Based on diesel fuel with a specific gravity of 0.85 and conforming to TS EN590

Class A2

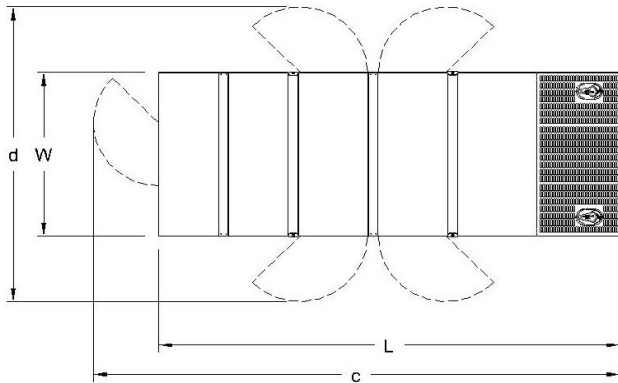

Diesel Engine

Manufacturer :	Cummins
Engine Model :	S3.8G4
No. of Cylinders / Alignment :	4L
Bore / Stroke [mm] :	97 / 128
Compression Ratio :	17,5/1
Displacement [lt] :	3,8
Engine Speed [rpm] :	1500
Gross Engine Power ESP / PRP [kW] :	43,4 / 38,7

Generator

Manufacturer :	Leroy Somer
Alternator Model :	TAL042E
Bearings Type :	Single
Insulation Class :	H
Winding Pitch :	2/3
No. of Wires Terminal :	4
Frequency / Poles :	50Hz / 4p
Voltage (Ph-Ph / Ph-N) :	400V / 230V
Output Power (163°C / 27°C) :	45 kVA / 36 kW

Prime Power (PRP)

A Prime rated generator set is capable of providing power to a varying load for an unlimited number of hours per year. Ten percent overload is allowed at one in 12 hours.

Emergency Standby Power (ESP)

A Standby rated generator set is capable of providing max. power to a varying load for 200 hours per year. No overload is allowed.

Standard Reference Conditions

A specified values are given for 25°C ambient temperature, 100m above sea level and 30% relative humidity.

Dimensions & Weights

	L x W x H (mm) / c x d (mm)	Dry (kg) / Wet (kg)
Canopy :	2200 x 1000 x 1680 / TBA	1390 kg
	L x W x H (mm) / a x b x h (mm)	Dry (kg) / Wet (kg)
W/O Canopy :	1600 x 900 x 1280 / 500 x 500 x 570	918 kg

Dry = Without any liquid

Wet = With lube oil, coolant and fuel

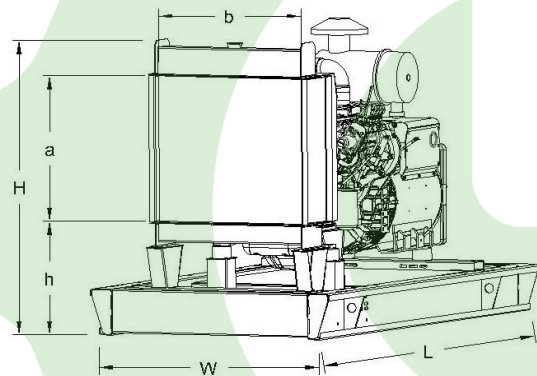

Air Intake System :	Natural Aspiration
Governor Type / Class 8528 :	Mechanical / G2
Total Oil Capacity [lt] :	11
Oil Type :	API CI-4 / 15W-40
Cooling System Capacity [lt] :	11
Recommended Fuel :	TS EN590, Class A2 Diesel
Emissions Compliance :	N/A
Housing - Flywheel :	SAE 3/10

Regulation Type / Model :	AVR	
Protection Class :	IP23	
Efficiency :	88,4%	
Voltage Regulation (Steady State) :	± 1.0%	
THD (Total Harmonic Distortion) :	< 2.0% w/o load/ < 5 % on load	
	15%	30 kVA
Voltage Dip.	25%	55 kVA
	30%	70 kVA

f = 50Hz, cos φ = 0,6 Motor Starting SHUNT is for given.