

GENERATOR SET

Power Ratings

Voltage, Frequency 400V, 50Hz cosφ = 0.8	PRP	ESP
	2000kVA / 1600kW	2200kVA / 1760kW

Engine Make / Model :	Cummins - QSK60G4
Generator Make / Model :	Leroy Somer - LSA 52.3S6
Control Panel :	ComAp Inteligen AMF9
Charge Alternator [V / A] :	24V / 55A
Battery Charger [V / A] :	24 / 5
Battery / Capacity [V / Ah] :	4 x 150 Ah
Block Water Heater [W] :	2 x 2000 W / 230V
ATS Model / Length x Width x Depth * :	3200A / 1600 x 1700 x 700

Fuel Consumption

Load	110%	100%	75%	50%
[lt / h]	437	394	291	200

Fuel Tank Capacity [lt - h] : 3600 ltrs (EXT) for open skid and canopied.

Based on diesel fuel with a specific gravity of 0.85 and conforming to TS EN590 Class A2

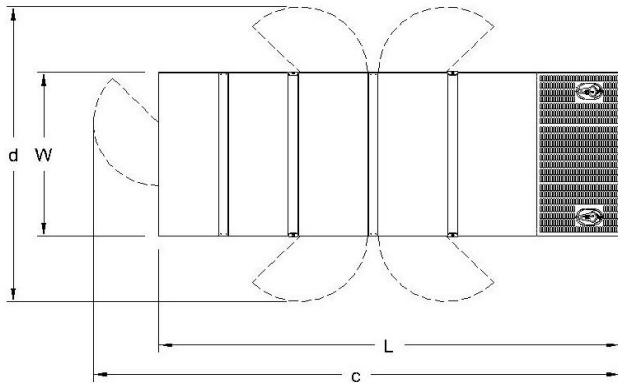

Diesel Engine

Manufacturer :	Cummins
Engine Model :	QSK60G4
No. of Cylinders / Alignment :	16V
Bore / Stroke [mm] :	159 / 190
Compression Ratio :	14,5/1
Displacement [lt] :	60,2
Engine Speed [rpm] :	1500
Gross Engine Power ESP / PRP [kW] :	1915 / 1730

Generator

Manufacturer :	Leroy Somer
Alternator Model :	LSA 52.3S6
Bearings Type :	Single
Insulation Class :	H
Winding Pitch :	2/3
No. of Wires Terminal :	6
Frequency / Poles :	50Hz / 4p
Voltage (Ph-Ph / Ph-N) :	400V / 230V
Output Power (163°C / 27°C) :	2200 kVA / 1760 kW

*Arep is standard, PMG is optional

Prime Power (PRP)

A Prime rated generator set is capable of providing power to a varying load for an unlimited number of hours per year. Ten percent overload is allowed at one in 12 hours.

Emergency Standby Power (ESP)

A Standby rated generator set is capable of providing max. power to a varying load for 200 hours per year. No overload is allowed.

Standard Reference Conditions

A specified values are given for 25°C ambient temperature, 100m above sea level and 30% relative humidity.

Dimensions & Weights

	L x W x H (mm) / c x d (mm)	Wet (kg)
Canopy :	65000 x 2700 x 4370 / TBA	14850 kg
	L x W x H (mm) / a x b x h (mm)	Wet (kg)
W/O Canopy :	6200 x 2500 x 3400 / 2200 x 2247 x 663	12880 kg

Dry = Without any liquid

Wet = With lube oil, coolant and fuel

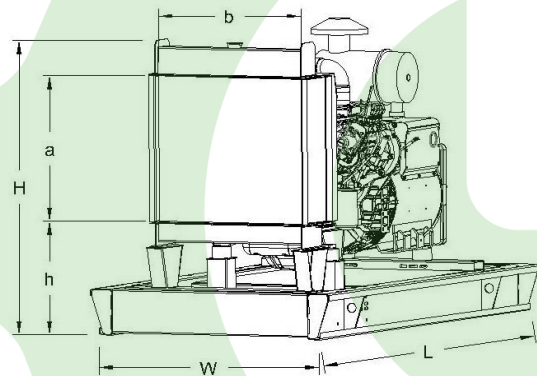

Air Intake System :	Turbo Charged, After Cooled
Governor Type / Class 8528 :	Electronic / G2
Total Oil Capacity [lt] :	280
Oil Type :	API CI-4 / 15W-40
Cooling System Capacity [lt] :	242
Recommended Fuel :	TS EN590, Class A2 Diesel
Emissions Compliance :	TA Luft
Housing - Flywheel :	SAE 0

Regulation Type / Model :	AVR / D510C	
Protection Class :	IP23	
Efficiency :	95,9%	
Voltage Regulation (Steady State) :	± 0.5%	
THD (Total Harmonic Distortion) :	< 4% w/o load/	
	15%	1700 kVA
Voltage Dip.	25%	3350 kVA
	30%	4420 kVA

f = 50Hz, cos φ = 0,8 is for given.