

## GENERATOR SET

### Power Ratings

Voltage, Frequency	PRP	ESP
400V, 50Hz cosφ = 0.8	1545kVA / 1236kW	1700kVA / 1360kW
Engine Make / Model :	Cummins - QSK50G4	
Generator Make / Model :	Leroy Somer - LSA 50.2VL10	
Control Panel :	ComAp Inteligen AMF9	
Charge Alternator [V / A] :	24V / 55A	
Battery Charger [V / A] :	24 / 5	
Battery / Capacity [V / Ah] :	4 x 150 Ah	
Block Water Heater [W] :	2 x 2000 W / 230V	
ATS Model / Length x Width x Depth * :	2500 A / 1400 x 1700 x 700	

### Fuel Consumption

Load	110%	100%	75%	50%
[lt / h]	373	338	258	183

Fuel Tank Capacity [lt - h] : 2000 ltrs (EXT) for open skid and canopied.

Based on diesel fuel with a specific gravity of 0.85 and conforming to TS EN590 Class A2

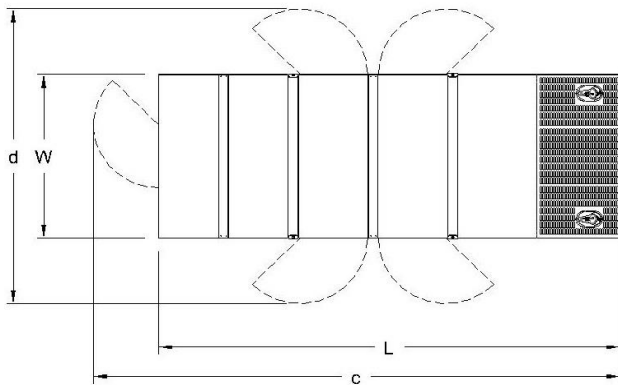

### Diesel Engine

Manufacturer :	Cummins
Engine Model :	QSK50G4
No. of Cylinders / Alignment :	16V
Bore / Stroke [mm] :	159 / 159
Compression Ratio :	14,9/1
Displacement [lt] :	50,3
Engine Speed [rpm] :	1500
Gross Engine Power ESP / PRP [kW] :	1477 / 1328

### Generator

Manufacturer :	Leroy Somer
Alternator Model :	LSA 50.2VL10
Bearings Type :	Single
Insulation Class :	H
Winding Pitch :	2/3
No. of Wires Terminal :	6
Frequency / Poles :	50Hz / 4p
Voltage (Ph-Ph / Ph-N) :	400V / 230V
Output Power ( 163°C / 27°C ) :	1800 kVA / 1440 kW

\*Arep is standard, PMG is optional

### Prime Power (PRP)

A Prime rated generator set is capable of providing power to a varying load for an unlimited number of hours per year. Ten percent overload is allowed at one in 12 hours.

### Emergency Standby Power (ESP)

A Standby rated generator set is capable of providing max. power to a varying load for 200 hours per year. No overload is allowed.

### Standard Reference Conditions

A specified values are given for 25°C ambient temperature, 100m above sea level and 30% relative humidity.

### Dimensions & Weights

	L x W x H (mm) / c x d (mm)	Dry (kg) / Wet (kg)
Canopy :	6500 x 2450 x 2800 / TBA	14800 kg
	L x W x H (mm) / a x b x h (mm)	Dry (kg) / Wet (kg)
W/O Canopy :	5750 x 2050 x 2600 / 1800 x 1885 553	11040 kg

Dry = Without any liquid

Wet = With lube oil, coolant and fuel

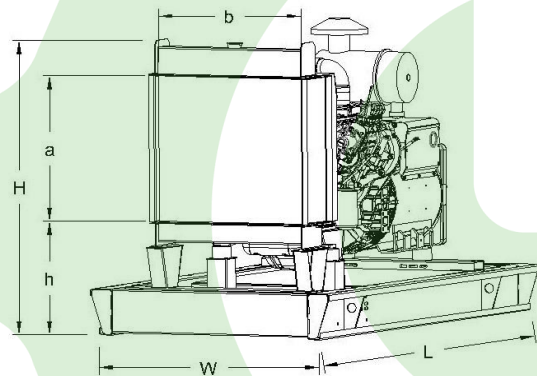

Air Intake System :	Turbo Charged
Governor Type / Class 8528 :	Electronic / G2
Total Oil Capacity [lt] :	235
Oil Type :	API CI-4 / 15W-40
Cooling System Capacity [lt] :	294
Recommended Fuel :	TS EN590, Class A2 Diesel
Emissions Compliance :	Tier 2
Housing - Flywheel :	SAE 0

Regulation Type / Model :	AVR / R450
Protection Class :	IP23
Efficiency (Pf 0,8 Prime) :	95,7%
Voltage Regulation (Steady State) :	± 0.5%
THD (Total Harmonic Distortion) :	< 3,5% w/o load/ < 3,5 % on load
	15% 1740 kVA
Voltage Dip.	25% 3250 kVA
	30% 4200 kVA

f = 50Hz, cosφ = 0,6, Arep or PMG system is for given.