

GENERATOR SET

Power Ratings

Voltage, Frequency	PRP	ESP
400V, 50Hz cosφ = 0.8	1000kVA / 800kW	1100kVA / 880kW
Engine Make / Model :	Cummins - QST30G4	
Generator Make / Model :	Leroy Somer - TAL049E	
Control Panel :	ComAp Inteligen AMF9	
Charge Alternator [V / A] :	24V / 35A	
Battery Charger [V / A] :	24 / 5	
Battery / Capacity [V / Ah] :	4 x 150 Ah	
Block Water Heater [W] :	2 X 2000 W / 230V	
ATS Model / Length x Width x Dept * :	ATS 1600A / 1100X2100X600	

Fuel Consumption

Load	110%	100%	75%	50%
[lt / h]	224	202	151	102

Fuel Tank Capacity [lt - h] : 2000 ltrs (EXT) open skid 1815 ltrs (EXT) canopied.

Based on diesel fuel with a specific gravity of 0.85 and conforming to TS EN590

Class A2

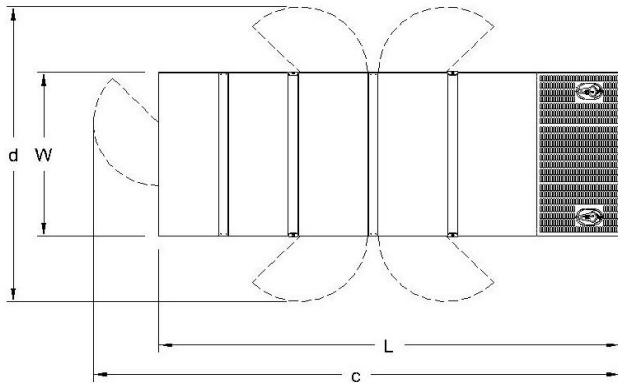

Diesel Engine

Manufacturer :	Cummins
Engine Model :	QST30G4
No. of Cylinders / Alignment :	12V
Bore / Stroke [mm] :	140 / 165,1
Compression Ratio :	14,0/1
Displacement [lt] :	30,5
Engine Speed [rpm] :	1500
Gross Engine Power ESP / PRP [kW] :	970 / 880

Generator

Manufacturer :	Leroy Somer
Alternator Model :	TAL049E
Bearings Type :	Single
Insulation Class :	H
Winding Pitch :	2/3
No. of Wires Terminal :	6
Frequency / Poles :	50Hz / 4p
Voltage (Ph-Ph / Ph-N) :	400V / 230V
Output Power (163°C / 27°C) :	1100 kVA / 880 kW

Prime Power (PRP)

A Prime rated generator set is capable of providing power to a varying load for an unlimited number of hours per year. Ten percent overload is allowed at one in 12 hours.

Emergency Standby Power (ESP)

A Standby rated generator set is capable of providing max. power to a varying load for 200 hours per year. No overload is allowed.

Standard Reference Conditions

A specified values are given for 25°C ambient temperature, 100m above sea level and 30% relative humidity.

Dimensions & Weights

	L x W x H (mm) / c x d (mm)	Wet (kg)
Canopy :	4800 x 2000 x 3270 / TBA	10235 kg
	L x W x H (mm) / a x b x h (mm)	Wet (kg)
W/O Canopy :	4450 x 1750 x 2450 / 1570 x 1670 485	8735 kg

Dry = Without any liquid

Wet = With lube oil, coolant and fuel

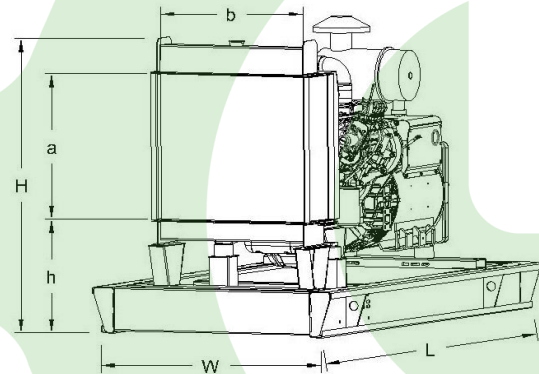

Air Intake System :	Turbo Charged
Governor Type / Class 8528 :	Electronic / G2
Total Oil Capacity [lt] :	154
Oil Type :	API CI-4 / 15W-40
Cooling System Capacity [lt] :	192
Recommended Fuel :	TS EN590, Class A2 Diesel
Emissions Compliance :	N/A
Housing - Flywheel :	SAE 0

Regulation Type / Model :	AVR / R150	
Protection Class :	IP23	
Efficiency (Pf 0,8 Prime) :	95,2%	
Voltage Regulation (Steady State) :	± 1.0%	
THD (Total Harmonic Distortion) :	< 3,5% w/o load/ < 5 % on load	
	15%	695 kVA
Voltage Dip.	25%	1300 kVA
	30%	1670 kVA

f = 50Hz, cos φ = 0,6, motor starting is SHUNT is for given.