

## GENERATOR SET

### Power Ratings

Voltage, Frequency	PRP	ESP
400V, 50Hz cosφ = 0.8	816kVA / 653kW	900kVA / 720kW
Engine Make / Model :	Baudouin - 12M26G900/5	
Generator Make / Model :	Leroy Somer - TAL049C	
Control Panel :	ComAp AMF 9 Lite	
Charge Alternator [V / A] :	24.0 / 55-Negative	
Battery Charger [V / A] :	27.3 / 5	
Battery / Capacity [V / Ah] :	2 x (12 / 150)	
Block Water Heater [W] :	2X2000 with pump	
ATS Model / Length x Width x Dept * :	1600A / 1100x2100x600	

### Fuel Consumption

Load	110%	100%	75%	50%
[lt / h]	190,5	172,5	130,4	91
Fuel Tank Capacity [lt] : External fuel tank	1500			

Based on diesel fuel with a specific gravity of 0.85 and conforming to TS EN590

Class A2

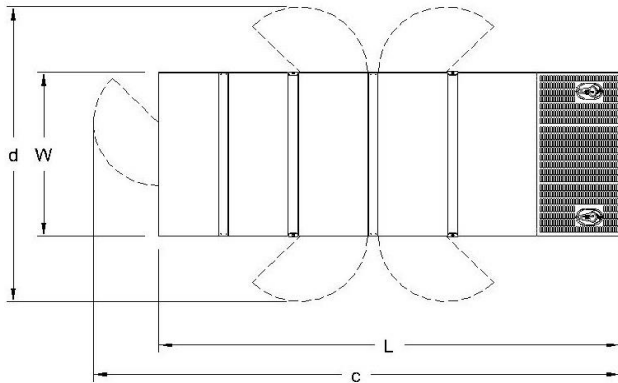

### Diesel Engine

Manufacturer :	Baudouin
Engine Model :	12M26G900/5
No. of Cylinders / Alignment :	12 / V
Bore / Stroke [mm] :	150 / 150
Compression Ratio :	15,7 : 1
Displacement [lt] :	31,8
Engine Speed [rpm] :	1500
Gross Engine Power ESP / PRP [kW] :	725 / 793

### Generator

Manufacturer :	Leroy Somer
Alternator Model :	TAL049C
Bearings Type :	Single
Insulation Class :	H
Winding Pitch :	2/3
No. of Wires Terminal :	6
Frequency / Poles :	50Hz / 4p
Voltage (Ph-Ph / Ph-N) :	400V / 230V
Output Power ( 163°C / 27°C ) :	910kVA / 728kW

### Prime Power (PRP)

A Prime rated generator set is capable of providing power to a varying load for an unlimited number of hours per year. Ten percent overload is allowed at one in 12 hours.

### Emergency Standby Power (ESP)

A Standby rated generator set is capable of providing max. power to a varying load for 200 hours per year. No overload is allowed.

### Standard Reference Conditions

A specified values are given for 25°C ambient temperature, 100m above sea level and 30% relative humidity.

### Dimensions & Weights

	L x W x H (mm) / c x d (mm)	Wet (kg)
Canopy :	5000X2200X3430 / TBA	7800
	L x W x H (mm) / a x b x h (mm)	Wet (kg)
W/O Canopy :	4200X2020X2400 / 1770 X 1800 X 240	6300

Dry = Without any liquid

Wet = With lube oil, coolant and fuel

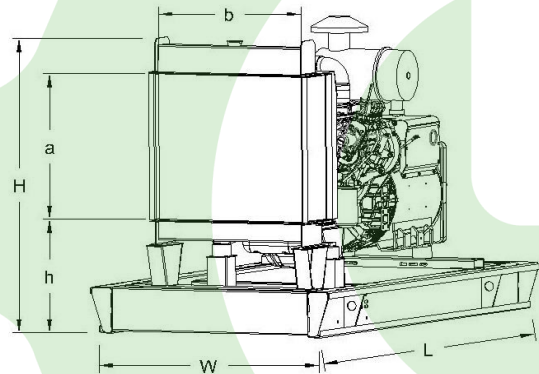

Air Intake System :	Turbocharged & Intercooled
Governor Type / Class 8528 :	Electronic / G2
Total Oil Capacity [lt] :	114
Oil Type :	API CI-4, CH4/ 15W-40
Cooling System Capacity [lt] :	191
Recommended Fuel :	TS EN590, Class A2 Diesel
Emissions Compliance :	N/A
Housing - Flywheel :	0-18

Regulation Type / Model :	AVR / R150	
Protection Class :	IP23	
Efficiency :	94.0%	
Voltage Regulation (Steady State) :	± 1.0%	
THD (Total Harmonic Distortion) :	< 3.5%	
	15%	580kVA
Voltage Dip.	25%	1100kVA
	30%	1400kVA

f = 50Hz, Voltage dip is given for Locked rotor at P.F.=0.6 .