

GENERATOR SET

Power Ratings

Voltage, Frequency	PRP	ESP
400V, 50Hz cosφ = 0.8	498,8kVA / 399kW	548kVA / 438,4kW

Engine Make / Model :	Baudouin - 6M26G550/5
Generator Make / Model :	Leroy Somer - TAL047C
Control Panel :	ComAp AMF 9 Lite
Charge Alternator [V / A] :	24.0 / 55-Negative
Battery Charger [V / A] :	27.3 / 5
Battery / Capacity [V / Ah] :	2 x 120 Ah
Block Water Heater [W, V] :	1500 W , 230 V
ATS Model / Length x Width x Dept * :	800A / 1000x850x320

Fuel Consumption

Load	110%	100%	75%	50%
[lt / h]	116,9	104,9	78,4	53,6
Fuel Tank Capacity [lt] : Open skid / Canopied :	900 / 650			

Based on diesel fuel with a specific gravity of 0.85 and conforming to TS EN590 Class A2

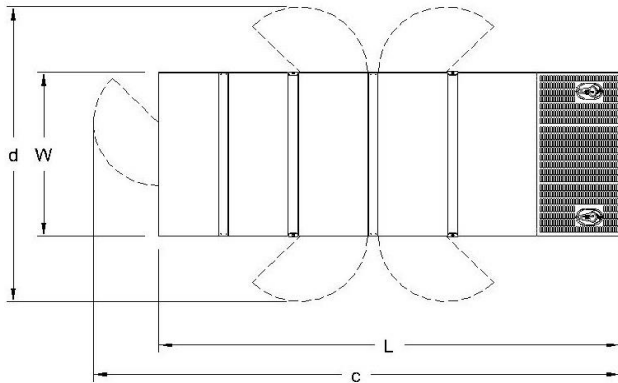

Diesel Engine

Manufacturer :	Baudouin
Engine Model :	6M26G550/5
No. of Cylinders / Alignment :	6 / L
Bore / Stroke [mm] :	150 / 150
Compression Ratio :	15,7 : 1
Displacement [lt] :	15.9
Engine Speed [rpm] :	1500
Gross Engine Power ESP / PRP [kW] :	448 / 490

Generator

Manufacturer :	Leroy Somer
Alternator Model :	TAL047C
Bearings Type :	Single
Insulation Class :	H
Winding Pitch :	2/3
No. of Wires Terminal :	6
Frequency / Poles :	50Hz / 4p
Voltage (Ph-Ph / Ph-N) :	400V / 230V
Output Power (163°C / 27°C) :	550kVA / 440kW

Prime Power (PRP)

A Prime rated generator set is capable of providing power to a varying load for an unlimited number of hours per year. Ten percent overload is allowed at one in 12 hours.

Emergency Standby Power (ESP)

A Standby rated generator set is capable of providing max. power to a varying load for 200 hours per year. No overload is allowed.

Standard Reference Conditions

A specified values are given for 25°C ambient temperature, 100m above sea level and 30% relative humidity.

Dimensions & Weights

	L x W x H (mm) / c x d (mm)	Wet (kg)
Canopy :	3900X1800X3130 / TBA	5030
	L x W x H (mm) / a x b x h (mm)	Wet (kg)
W/O Canopy :	3600X1650X2050 / 930 x 1040 x 605	4025

Dry = Without any liquid

Wet = With lube oil, coolant and fuel

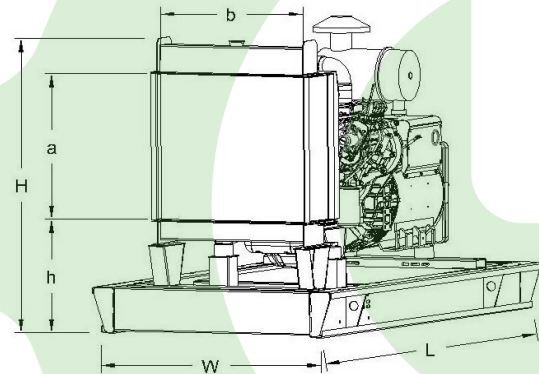

Air Intake System :	Turbocharged & Intercooled
Governor Type / Class 8528 :	Electronic / G2
Total Oil Capacity [lt] :	61
Oil Type :	API CI-4, CH4/ 15W-40
Cooling System Capacity [lt] :	129
Recommended Fuel :	TS EN590, Class A2 Diesel
Emissions Compliance :	N/A
Housing - Flywheel :	1-14

Regulation Type / Model :	AVR / R150	
Protection Class :	IP23	
Efficiency :	93.9%	
Voltage Regulation (Steady State) :	± 1.0%	
THD (Total Harmonic Distortion) :	< 1.5%	
	15%	300kVA
Voltage Dip.	25%	580kVA
	29%	725kVA

f = 50Hz, Voltage dip is given for Locked rotor at P.F.=0.6 .