

GENERATOR SET

Power Ratings

Voltage, Frequency	PRP	ESP
400V, 50Hz cosφ = 0.8	15kVA / 12kW	17kVA / 13,6kW

Engine Make / Model :	Baudouin - 4M06G17/5
Generator Make / Model :	Leroy Somer - TAL040E
Control Panel :	ComAp AMF 9 Lite
Charge Alternator [V / A] :	12.0 / 55-Negative
Battery Charger [V / A] :	12 / 5
Battery / Capacity [V / Ah] :	1 x (12V / 50Ah)
Block Water Heater [W] :	500 W
ATS Model / Length x Width x Height * :	32A / 550x450x200

Fuel Consumption

Load	110%	100%	75%	50%
[lt / h]	5,36	4,76	3,69	2,62
Fuel Tank Capacity [lt] : Open skid / Canopied :	100 / 50			

Based on diesel fuel with a specific gravity of 0.85 and conforming to TS EN590 Class A2

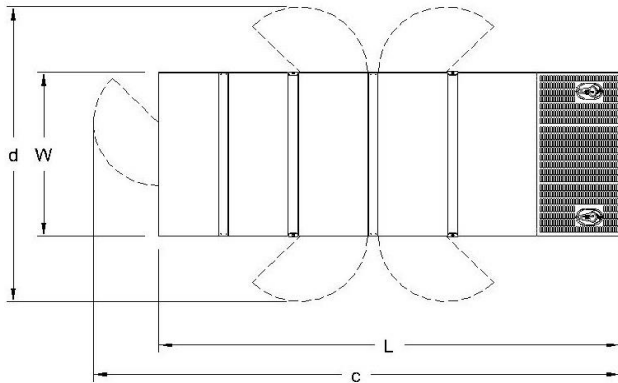

Diesel Engine

Manufacturer :	Baudouin
Engine Model :	4M06G17/5
No. of Cylinders / Alignment :	4L
Bore / Stroke [mm] :	89 / 92
Compression Ratio :	17,5 : 1
Displacement [lt] :	2,3
Engine Speed [rpm] :	1500
Gross Engine Power ESP / PRP [kW] :	20 / 18

Generator

Manufacturer :	Leroy Somer
Alternator Model :	TAL040E
Bearings Type :	Single
Insulation Class :	H
Winding Pitch :	2/3
No. of Wires Terminal :	6
Frequency / Poles :	50Hz / 4p
Voltage (Ph-Ph / Ph-N) :	400V / 230V
Output Power (163°C / 27°C) :	19,5kVA / 15,5kW

Prime Power (PRP)

A Prime rated generator set is capable of providing power to a varying load for an unlimited number of hours per year. Ten percent overload is allowed at one in 12 hours.

Emergency Standby Power (ESP)

A Standby rated generator set is capable of providing max. power to a varying load for 200 hours per year. No overload is allowed.

Standard Reference Conditions

A specified values are given for 25°C ambient temperature, 100m above sea level and 30% relative humidity.

Dimensions & Weights

	L x W x H (mm) / c x d (mm)	Wet (kg)
Canopy :	1750X950X1420 / TBA	760
	L x W x H (mm) / a x b x h (mm)	Wet (kg)
W/O Canopy :	1300X850X1100 / 513 x 530 x 4800	540

Dry = Without any liquid

Wet = With lube oil, coolant and fuel

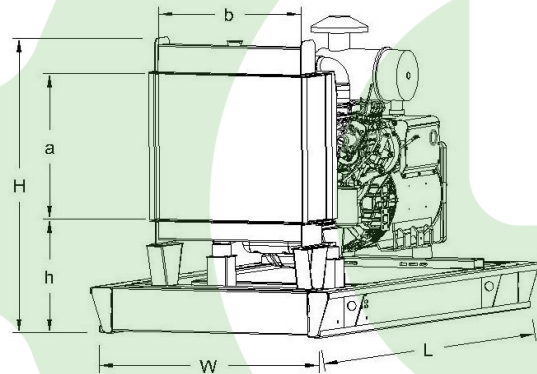

Air Intake System :	Naturally Aspirated
Governor Type / Class 8528 :	Mechanic
Total Oil Capacity [lt] :	11,6
Oil Type :	API CI-4, CH4/ 15W-40
Cooling System Capacity [lt] :	16
Recommended Fuel :	TS EN590, Class A2 Diesel
Emissions Compliance :	N/A
Housing - Flywheel :	SAE4/7,5

Regulation Type / Model :	AVR / R120
Protection Class :	IP23
Efficiency :	86.6%
Voltage Regulation (Steady State) :	± 1.0%
THD (Total Harmonic Distortion) :	< 3.5% w/o load/ < 5 % on load
	15% 14kVA
Voltage Dip.	25% 26kVA
	30% 33kVA

f = 50Hz, Voltage dip is given for Locked rotor at P.F.=0.6 .