

GENERATOR SET

Power Ratings

Voltage, Frequency	PRP	ESP
400V, 50Hz cosφ = 0.8	N/A	1744kVA / 1395kW
Engine Make / Model :	Baudouin - 12M33G1700/5	
Generator Make / Model :	Leroy Somer - LSA50.2. VL10	
Control Panel :	ComAp AMF 9 Lite	
Charge Alternator [V / A] :	24.0 / 55-Negative	
Battery Charger [V / A] :	27.3 / 5	
Battery / Capacity [V / Ah] :	2 x (12 / 200)	
Block Water Heater [W] :	2X3000 with pump	
ATS Model / Length x Width x Height * :	2500A / 1400X1750X750	

Fuel Consumption

Load	110%	100%	75%	50%
[lt / h]	362,1	TBA	TBA	TBA
Fuel Tank Capacity [lt] : External fuel tank	2500			

Based on diesel fuel with a specific gravity of 0.85 and conforming to TS EN590 Class A2

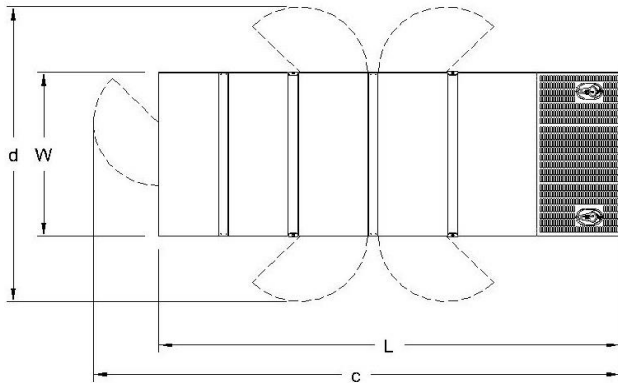

Diesel Engine

Manufacturer :	Baudouin
Engine Model :	12M33G1700/5
No. of Cylinders / Alignment :	16 / V
Bore / Stroke [mm] :	150 / 185
Compression Ratio :	15,0 : 1
Displacement [lt] :	52,3
Engine Speed [rpm] :	1500
Gross Engine Power ESP / PRP [kW] :	N/A / 1650

Generator

Manufacturer :	Leroy Somer
Alternator Model :	LSA50.2 VL10
Bearings Type :	Single
Insulation Class :	H
Winding Pitch :	2/3
No. of Wires Terminal :	6
Frequency / Poles :	50Hz / 4p
Voltage (Ph-Ph / Ph-N) :	400V / 230V
Output Power (163°C / 27°C) :	1800kVA / 1440kW

Prime Power (PRP)

A Prime rated generator set is capable of providing power to a varying load for an unlimited number of hours per year. Ten percent overload is allowed at one in 12 hours.

Emergency Standby Power (ESP)

A Standby rated generator set is capable of providing max. power to a varying load for 200 hours per year. No overload is allowed.

Standard Reference Conditions

A specified values are given for 25°C ambient temperature, 100m above sea level and 30% relative humidity.

Dimensions & Weights

	L x W x H (mm) / c x d (mm)	Dry (kg) / Wet (kg)
Canopy :	5600X2500X3770 / TBA	TBA
	L x W x H (mm) / a x b x h (mm)	Dry (kg) / Wet (kg)
W/O Canopy :	5200X2300X3100 / TBA	TBA

Dry = Without any liquid

Wet = With lube oil, coolant and fuel

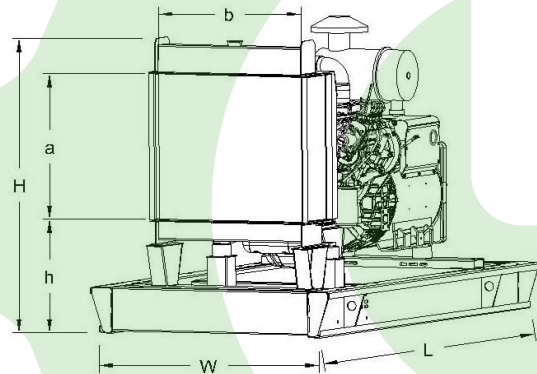

Air Intake System :	Turbocharged & Intercooled
Governor Type / Class 8528 :	Electronic / G2
Total Oil Capacity [lt] :	175
Oil Type :	API CI-4, CH4/ 15W-40
Cooling System Capacity [lt] :	TBA
Recommended Fuel :	TS EN590, Class A2 Diesel
Emissions Compliance :	N/A
Housing - Flywheel :	0-18

Regulation Type / Model :	AVR / R450	
Protection Class :	IP23	
Efficiency :	95.6%	
Voltage Regulation (Steady State) :	± 0.5%	
THD (Total Harmonic Distortion) :	< 3.5%	
	15%	1700kVA
Voltage Dip.	25%	3250kVA
	30%	4100kVA

f = 50Hz, Voltage dip is given for Locked rotor.