

GENERATOR SET

Power Ratings

Voltage, Frequency	PRP	ESP
400V, 50Hz cosφ = 0.8	41kVA / 32,8kW	45kVA / 36kW
Engine Make / Model :	ALR - AYD4NS38	
Generator Make / Model :	Leroy Somer / TAL042E	
Control Panel :	ComAp AMF 9 Lite	
Charge Alternator [V / A] :	14.0 / 55-Negative	
Battery Charger [V / A] :	13.7 / 5	
Battery / Capacity [V / Ah] :	1 x (12 / 60)	
Block Water Heater [W] :	500	
ATS Model / Length x Width x Dept * :	80A / 550x200x450	

Fuel Consumption

Load	110%	100%	75%	50%
[lt / h]		10		
Fuel Tank Capacity [lt] Open skid / Canopied :	120 / 105			

Based on diesel fuel with a specific gravity of 0.85 and conforming to TS EN590 Class A2

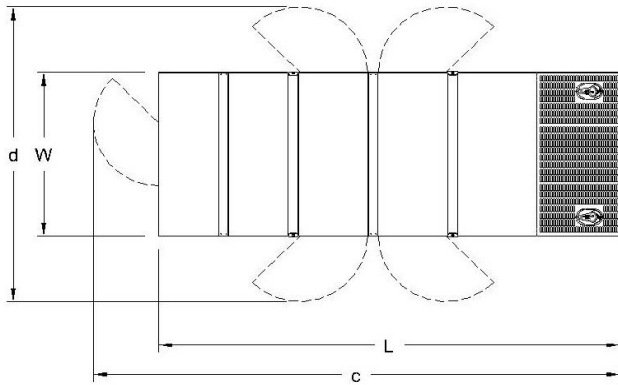

Diesel Engine

Manufacturer :	ALR
Engine Model :	AYD 4NS38
No. of Cylinders / Alignment :	4 / Inline
Bore / Stroke [mm] :	102 / 118
Compression Ratio :	18,0,1
Displacement [lt] :	3,875
Engine Speed [rpm] :	1500
Gross Engine Power ESP / PRP [kW] :	RFI / 36,3

Generator

Manufacturer :	Leroy Somer
Alternator Model :	TAL042E
Bearings Type :	Single
Insulation Class :	H
Winding Pitch :	2/3
No. of Wires Terminal :	4
Frequency / Poles :	50Hz / 4p
Voltage (Ph-Ph / Ph-N) :	400V / 230V
Output Power (163°C / 27°C) :	45 kVA / 36 kW

Prime Power (PRP)

A Prime rated generator set is capable of providing power to a varying load for an unlimited number of hours per year. Ten percent overload is allowed at one in 12 hours.

Emergency Standby Power (ESP)

A Standby rated generator set is capable of providing max. power to a varying load for 200 hours per year. No overload is allowed.

Standard Reference Conditions

A specified values are given for 25°C ambient temperature, 100m above sea level and 30% relative humidity.

Dimensions & Weights

	L x W x H (mm) / c x d (mm)	Wet (kg)
Canopy :	2100x1000x1570 / RFI	1125
	L x W x H (mm) / a x b x h (mm)	Wet (kg)
W/O Canopy :	1600X900X1220 / 490X520X590	975

Dry = Without any liquid

Wet = With lube oil, coolant and fuel

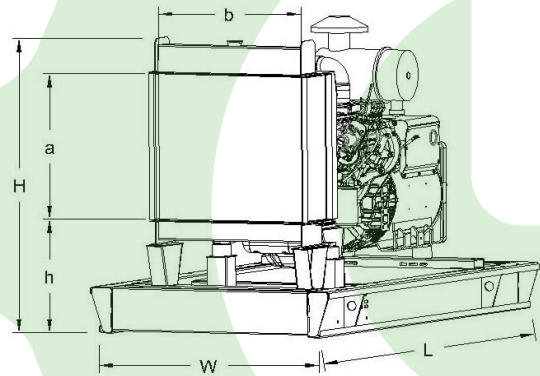

Air Intake System :	Nat. Aspirated
Governor Type / Class 8528 :	Mechanic / G1
Total Oil Capacity [lt] :	14
Oil Type :	API CI-4, CH4/ 15W-40
Cooling System Capacity [lt] :	10,46
Recommended Fuel :	TS EN590, Class A2 Diesel
Emissions Compliance :	-
Housing - Flywheel :	3-11.5

Regulation Type / Model :	AVR	
Protection Class :	IP23	
Efficiency :	88,4%	
Voltage Regulation (Steady State) :	± 1.0%	
THD (Total Harmonic Distortion) :	< 2.0% w/o load/ < 5 % on load	
	15%	30 kVA
Voltage Dip.	25%	55 kVA
	30%	70 kVA

f = 50Hz, cosφ = 0,6 Motor Starting SHUNT is for given.